



# City of Chicago



SO2021-631

Office of the City Clerk

## Document Tracking Sheet

<b>Meeting Date:</b>	2/24/2021
<b>Sponsor(s):</b>	Misc. Transmittal
<b>Type:</b>	Ordinance
<b>Title:</b>	Zoning Reclassification Map No. 1-G at 160 N Morgan St/180 N Morgan St - App No. 20631
<b>Committee(s) Assignment:</b>	Committee on Zoning, Landmarks and Building Standards

# FINAL FOR PUBLICATION

## ORDINANCE

**BE IT ORDAINED BY THE CITY COUNCIL OF THE CITY OF CHICAGO:**

**SECTION 1.** That the Chicago Zoning Ordinance be amended by changing all of the C1-2 Neighborhood Commercial District symbols and indications as shown on Map 1-G in the area bounded by:

North Morgan Street; the public alley north of and parallel to West Randolph Street; the vacated alley west of and parallel to North Morgan Street; the public alley south of and parallel to West Lake Street, a line 75.41 feet west of and parallel to North Morgan Street and West Lake Street

to those of a DX-7 Downtown Mixed-Use District.

**SECTION 2.** That the Chicago Zoning Ordinance be amended by changing all of the DX-7 Downtown Mixed-Use District symbols and indications as shown on Map 1-G in the area bounded by:

North Morgan Street; the public alley north of and parallel to West Randolph Street; the vacated alley west of and parallel to North Morgan Street; the public alley south of and parallel to West Lake Street; a line 75.41 feet west of and parallel to North Morgan Street and West Lake Street

to those of a Residential-Business Planned Development which is hereby established in the area above described, subject to such use and bulk regulations as are set forth in the Plan of Development herewith attached and made a part thereof and to no others.

**SECTION 3.** This Ordinance shall be in force and effect from and after its passage and due publication.

Address: 160 N Morgan / 180 N Morgan, Chicago, Illinois, 60607

EAST\179043386 6

# FINAL FOR PUBLICATION

## RESIDENTIAL-BUSINESS PLANNED DEVELOPMENT NO. \_\_\_\_\_ PLANNED DEVELOPMENT STATEMENTS

1. The area delineated herein as Planned Development Number TBD (Planned Development) consists of approximately 26,275 square feet of property which is depicted on the attached Planned Development Boundary and Property Line Map (Property). 160 N. Morgan, LLC is the owner of the Property and the "Applicant" for this Planned Development.
2. The requirements, obligations and conditions contained within this Planned Development shall be binding upon the Applicant, its successors and assigns and, if different than the Applicant, the legal title holders and any ground lessors. All rights granted hereunder to the Applicant shall inure to the benefit of the Applicant's successors and assigns and, if different than the Applicant, the legal title holder and any ground lessors. Furthermore, pursuant to the requirements of Section 17-8-0400 of the Chicago Zoning Ordinance, the Property, at the time of application for amendments, modifications or changes (administrative, legislative or otherwise) to this Planned Development are made, shall be under single ownership or designated control. *Single designated control is defined in Section 17-8-0400.*
3. All applicable official reviews, approvals or permits are required to be obtained by the Applicant or its successors, assignees or grantees. Any dedication or vacation of streets or alleys or grants of easements or any adjustment of the right-of-way shall require a separate submittal to the Department of Transportation on behalf of the Applicant or its successors, assignees or grantees.

Any requests for grants of privilege, or any items encroaching on the public way, shall be in compliance with the Planned Development.

Ingress or egress shall be pursuant to the Planned Development and may be subject to the review and approval of the Departments of Planning and Development and Transportation. Closure of all or any public street or alley during demolition or construction shall be subject to the review and approval of the Department of Transportation.

All work proposed in the public way must be designed and constructed in accordance with the Department of Transportation Construction Standards for Work in the Public Way and in compliance with the Municipal Code of Chicago. Prior to the issuance of any Part II approval, the submitted plans must be approved by the Department of Transportation.

Pursuant to a negotiated and executed Perimeter Restoration Agreement ("Agreement") by and between the Department of Transportation's Division of Infrastructure Management and the Applicant, the Applicant shall provide improvements and restoration of all public way adjacent to the property, which may include, but not be limited to, the following as shall be reviewed and determined by the Department of Transportation's Division of Infrastructure Management:

- Full width of streets
- Full width of alleys
- Curb and gutter
- Pavement markings
- Sidewalks
- ADA crosswalk ramps
- Parkway & landscaping

Applicant	160 N Morgan, LLC
Address	160 N Morgan / 180 N Morgan, Chicago, IL 60607
Introduced	February 24, 2021
Plan Commission	September 16, 2021

# FINAL FOR PUBLICATION

The Perimeter Restoration Agreement must be executed prior to any Department of Transportation and Planned Development Part II review permitting. The Agreement shall reflect that all work must comply with current Rules and Regulations and must be designed and constructed in accordance with the Department of Transportation's Construction Standards for work in the Public Way and in compliance with the Municipal Code of Chicago Chapter 10-20. Design of said improvements should follow the Department of Transportation's Rules and Regulations for Construction in the Public Way as well as The Street and Site Plan Design Guidelines. Any variation in scope or design of public way improvements and restoration must be approved by the Department of Transportation.

The applicant shall contribute funds toward the burial of utility lines currently located on ComEd poles in the north alley within the boundary of the PD should a cost sharing agreement among the neighboring property owners be reached.

4. This Plan of Development consists of 17 Statements; a Bulk Regulations Table; an Existing Zoning Map; an Existing Land Use Map; a Planned Development Boundary and Property Line Map; a Subarea Map; a Site Plan; a Landscape Plan; and Building Elevations (North, South, East and West) prepared by bKL Architecture and dated \_\_\_\_ submitted herein. In any instance where a provision of this Planned Development conflicts with the Chicago Building Code, the Building Code shall control. This Planned Development conforms to the intent and purpose of the Chicago Zoning Ordinance, and all requirements thereto, and satisfies the established criteria for approval as a Planned Development. In case of a conflict between the terms of this Planned Development Ordinance and the Chicago Zoning Ordinance, this Planned Development shall control.
5. The following uses are permitted in the area delineated herein as a Planned Development: Residential Above the Ground Floor; Office, Vacation Rental; Shared Housing; Animal Services (excluding overnight boarding and kennels); Business Equipment Sales and Service; Business Support Services; Communication Service Establishments; Eating and Drinking Establishments (all, including Taverns); Financial Services (excluding payday loan and pawn shops); Food and Beverage Retail Sales; Medical Service; Personal Service; General Retail Sales; Participant Sports and Recreation; Artisan Manufacturing, Production and Industrial Services (only as an accessory use to a principal retail use); Co-located Wireless Communication Facilities, accessory parking and non-accessory parking (up to 45% pursuant to Section 17-10-0503 [with documentation provided]), and incidental and accessory uses.
6. On-Premise signs and temporary signs, such as construction and marketing signs, shall be permitted within the Planned Development, subject to the review and approval of the Department of Planning and Development. Off-Premise signs are prohibited within the boundary of the Planned Development.
7. For purposes of height measurement, the definitions in the Chicago Zoning Ordinance shall apply. The height of any building shall also be subject to height limitations, if any, established by the Federal Aviation Administration.
8. The maximum permitted floor area ratio (FAR) for the Property shall be in accordance with the attached Bulk Regulations and Data Table. For the purpose of FAR calculations and measurements, the definitions in the Zoning Ordinance shall apply. The permitted FAR identified in the Bulk Regulations and Data Table has been determined using a net site area of 26,275 square feet and a base FAR of 7.0.

Applicant	160 N Morgan, LLC
Address	160 N Morgan / 180 N Morgan, Chicago, IL 60607
Introduced	February 24, 2021
Plan Commission	September 16, 2021

# FINAL FOR PUBLICATION

The Applicant acknowledges that the project has received a bonus FAR of 3.21, pursuant to Sec. 17-4-1000 of the Zoning Ordinance. With this bonus FAR, the total FAR for the Planned Development is 10.21. In exchange for the bonus FAR, the Applicant is required to make a corresponding payment, pursuant to Sections 17-4-1003-B & C, prior to the issuance of the first building permit for any building in the Planned Development; provided, however, if the Planned Development is constructed in phases, the bonus payment may be paid on a pro rata basis as the first building permit for each subsequent new building or phase of construction is issued. The bonus payment will be recalculated at the time of payment (including partial payments for phased developments) and may be adjusted based on changes in median land values in accordance with Section 17-4-1003-C.3

The bonus payment will be split between three separate funds, as follows: 80% to the Neighborhoods Opportunity Fund, 10% to the Citywide Adopt-a-Landmark Fund and 10% to the Local Impact Fund. In lieu of paying the City directly, the Department may: (a) direct developers to deposit a portion of the funds with a sister agency to finance specific local improvement projects; (b) direct developers to deposit a portion of the funds with a landmark property owner to finance specific landmark restoration projects; or, (c) approve proposals for in-kind improvements to satisfy the Local Impact portion of the payment.

9. Upon review and determination, Part II Review, pursuant to Section 17-13-0610, a Part II Review Fee shall be assessed by the Department of Planning and Development. The fee, as determined by staff at the time, is final and binding on the Applicant and must be paid to the Department of Revenue prior to the issuance of any Part II approval.
10. The Site and Landscape Plans shall be in substantial conformance with the Landscape Ordinance and any other corresponding regulations and guidelines, including Section 17-13-0800. Final landscape plan review and approval will be by the Department of Planning and Development. Any interim reviews associated with site plan review or Part II reviews, are conditional until final Part II approval.
11. The Applicant shall comply with Rules and Regulations for the Maintenance of Stockpiles promulgated by the Commissioners of the Departments of Streets and Sanitation, Fleet and Facility Management and Buildings, under Section 13-32-085, or any other provision of the Municipal Code of Chicago.
12. The terms and conditions of development under this Planned Development ordinance may be modified administratively, pursuant to Section 17-13-0611-A, by the Zoning Administrator upon the application for such a modification by the Applicant, its successors and assigns and, if different than the Applicant, the legal title holders and any ground lessors.
13. The Applicant acknowledges that it is in the public interest to design, construct and maintain the project in a manner which promotes, enables and maximizes universal access throughout the Property. Plans for all buildings and improvements on the Property shall be reviewed and approved by the Mayor's Office for People with Disabilities to ensure compliance with all applicable laws and regulations related to access for persons with disabilities and to promote the highest standard of accessibility.
14. The Applicant acknowledges that it is in the public interest to design, construct, renovate and maintain all buildings in a manner that provides healthier indoor environments, reduces operating costs and conserves energy and natural resources. The Applicant shall obtain the number of points necessary to meet the requirements of the Chicago Sustainable Development Policy, in effect at the time the Part II

Applicant	160 N Morgan, LLC
Address	160 N Morgan / 180 N Morgan, Chicago, IL 60607
Introduced	February 24, 2021
Plan Commission	September 16, 2021

# FINAL FOR PUBLICATION

review process is initiated for each improvement that is subject to the aforementioned Policy and must provide documentation verifying compliance.

15. The Applicant acknowledges that it is the policy of the City to maximize opportunities for Minority and Women-owned Business Enterprises (“M/WBEs”) and city residents to compete for contracts and jobs on construction projects approved through the planned development process. To assist the city in promoting and tracking such M/WBE and city resident participation, an applicant for planned development approval shall provide information at three points in the city approval process. First, the applicant must submit to DPD, as part of its application for planned development approval, an M/WBE Participation Proposal. The M/WBE Participation Proposal must identify the applicant’s goals for participation of certified M/WBE firms in the design, engineering and construction of the project, and of city residents in the construction work. The city encourages goals of 26% MBE and 6% WBE participation (measured against the total construction budget for the project or any phase thereof), and (ii) 50% city resident hiring (measured against the total construction work hours for the project or any phase thereof). The M/WBE Participation Proposal must include a description of the Applicant’s proposed outreach plan designed to inform M/WBEs and city residents of job and contracting opportunities. Second, at the time of the Applicant’s submission for Part II permit review for the project or any phase thereof, the Applicant must submit to DPD (a) updates (if any) to the Applicant’s preliminary outreach plan, (b) a description of the Applicant’s outreach efforts and evidence of such outreach, including, without limitation, copies of certified letters to M/WBE contractor associations and the ward office of the alderman in which the project is located and receipts thereof; (c) responses to the Applicant’s outreach efforts, and (d) updates (if any) to the applicant’s M/WBE and city resident participation goals. Third, prior to issuance of a Certificate of Occupancy for the project or any phase thereof, the Applicant must provide DPD with the actual level of M/WBE and city resident participation in the project or any phase thereof, and evidence of such participation. In addition to the foregoing, DPD may request such additional information as the department determines may be necessary or useful in evaluating the extent to which M/WBEs and city residents are informed of and utilized in planned development projects. All such information will be provided in a form acceptable to the Zoning Administrator. DPD will report the data it collects regarding projected and actual employment of M/WBEs and city residents in planned development projects twice yearly to the Chicago Plan Commission and annually to the Chicago City Council and the Mayor.
16. The Applicant acknowledges and agrees that the rezoning of the Property from C1-2 Neighborhood Commercial District, to DX-7 Downtown Mixed-Use District, and then to this Residential-Business Planned Development (“PD”) \_\_\_\_\_ is an “entitlement” that triggers the requirements of Section 2-44-085 of the Municipal Code of Chicago (the “ARO”). The PD is located in an “inclusionary housing area” within the meaning of the ARO. The Applicant intends to construct a 282-unit rental building. Developers of rental projects in inclusionary areas with 30 or more units must provide between 10% and 20% of the units in the residential development as affordable, depending on the average depth of affordability provided, as described in Section 2-44-85(F)(2). Regardless of the applicable percentage of affordable units in the rental project, developers must construct at least 25% of the affordable units on-site and another 25% on-site or off-site (collectively, the “Required Units”), and may satisfy the balance of their affordable housing obligation through: (a) the establishment of additional on-site or off-site affordable units; (b) payment of a fee in lieu of the establishment of on-site or off-site affordable units; or (c) any combination thereof. All on-site affordable units must be accessible dwelling units, as required under subsection (W)(10) of the ARO, and developers must give preference in leasing accessible units to people with disabilities. All off-site affordable units must have at least two bedrooms and must be located in a downtown district, inclusionary housing area, or community preservation area.

Applicant	160 N Morgan, LLC
Address	160 N Morgan / 180 N Morgan, Chicago, IL 60607
Introduced:	February 24, 2021
Plan Commission	September 16, 2021

# FINAL FOR PUBLICATION

Whether on-site or off-site, developers must give preference in leasing affordable units of two bedrooms or more to multi-person households, as specified in the ARO rules. If a residential project is located in a transit-served location, off-site units must be located in a substantially comparable transit-served location. The Applicant has elected the 20% option as set forth in the chart in subsection (F)(2) of the ARO. As a result, the Applicant's affordable housing obligation is 56.4 affordable units (20% of 282) and 50% of those units are Required Units. Pursuant to subsection (T) of the ARO, the Applicant must either pay a fractional in lieu fee or provide an additional unit on-site or off-site to satisfy the fractional obligation. The Applicant has agreed to satisfy its affordable housing obligation by (a) providing 28 Required Units on-site in the rental building in the PD, as set forth in the Affordable Housing Profile ("AHP") attached hereto, and (b) making a cash payment in the amount of \$5,337,467.6 in total (28.4 x \$187,939), as adjusted in accordance with the ARO ("Cash Payment") in lieu of the development of the remaining 28.4 ARO units. Notwithstanding subsection (M) of the ARO, Applicant may pay the Cash Payment into an escrow account controlled by the City of Chicago (the "City") at the time that the Applicant records the Inclusionary Housing Agreement ("IHA"). The City shall release the escrowed funds to the developer of 2548 South Federal Street, Chicago, IL (the "SL Solar Lofts Developer"), or, at the City's option, to the construction escrow account, at the closing of the construction financing for development at 2548 South Federal Street, provided that the SL Solar Lofts Developer has executed and recorded an IHA (or other regulatory agreement acceptable to the City) obligating the SL Solar Lofts Developer to construct the 28 affordable housing units at 2548 South Federal Street and, if applicable, has entered into a construction escrow agreement acceptable to the City. The off-site development will be a newly renovated 44-unit residential development. The off-site development requires an entitlement to build its planned 44 dwelling units. As a result, the off-site development's affordable housing obligation is 4 affordable units (20% of its 16 market rate units, rounded up). In total, the SL Solar Lofts Developer plans to provide 32 affordable units at 2548 South Federal Street (its obligation of 4 affordable units and Applicant's obligation of 28 affordable units) and 12 market rate units. The off-site development will be sustainable with an energy efficient building design, rooftop solar photovoltaic system, energy efficient appliances, IoT integration and electric vehicle (EV) charging stations. If the closing of the construction financing for the off-site development does not occur by December 21, 2022, the escrowed funds will be transferred, at the City's direction, to the Affordable Housing Opportunity Fund and the ARO obligation for SL Solar Lofts Developer's will be 8.8 affordable units (20% of its 44 dwelling units). The Applicant agrees that the on-site affordable rental units must be affordable to households with a range of incomes averaging 60% of the Chicago Primary Metropolitan Statistical Area Median Income ("AMI"), as updated annually, provided that (x) the maximum income level for any affordable unit may not exceed 80% of the AMI, (y) at least one-third must be affordable to households at or below 50% of the AMI, of which one-sixth must be affordable to households at or below 40% of the AMI, and (z) all income levels must be multiples of 10% of the AMI. If the Applicant requests to change its method of compliance with the ARO after the passage of this PD, the Applicant shall update and resubmit the AHP to DOH for review and approval. DOH may adjust the AHP in accordance with the ARO without amending the PD, provided however, any request to relocate affordable units from on-site to an off-site location requires an informational presentation to the Plan Commission. Prior to the issuance of any building permits for any residential building in the PD, including, without limitation, excavation or foundation permits, the Applicant must execute and record the IHA, in accordance with subsection (N) of the ARO. The terms of the IHA and any amendments thereto are incorporated herein by this reference. The Applicant acknowledges and agrees that the IHA will be recorded against Subarea B of the PD, and will constitute a lien against such property. The Commissioner of DOH may enforce remedies for any breach of this Statement 16, including any breach of any IHA, and enter into settlement agreements with respect to any such breach, subject to the approval of the Corporation Counsel, without amending the PD. This statement does not

Applicant	160 N Morgan, LLC
Address	160 N Morgan / 180 N Morgan, Chicago, IL 60607
Introduced	February 24, 2021
Plan Commission	September 16, 2021

# FINAL FOR PUBLICATION

include all ARO requirements and options. It is intended to provide an overview of the application of the ARO to this PD. In the event of any conflict between this statement and the terms and conditions of the ARO, the ARO shall govern.

17. *This Planned Development shall be governed by Section 17-13-0612. Should this Planned Development ordinance lapse, the Commissioner of the Department of Planning and Development shall initiate a Zoning Map Amendment to rezone the property to the DX-7 Downtown Mixed-Use District.*

Applicant	160 N Morgan, LLC
Address	160 N Morgan / 180 N Morgan, Chicago, IL 60607
Introduced	February 24, 2021
Plan Commission	September 16, 2021



# FINAL FOR PUBLICATION

## RESIDENTIAL-BUSINESS PLANNED DEVELOPMENT NO. \_\_\_\_\_ BULK REGULATIONS AND DATA TABLE

Gross Site Area (sf).	40,942.14
Area of Public Rights-of-Way (sf):	14,667.14
Net Site Area (sf):	26,275
Subarea A:	7,564
Subarea B:	18,711
Maximum Floor Area Ratio:	10.21
Subarea A:	0.67 (5,052 sf)
Subarea B:	14.07
Maximum Permitted Dwelling Units:	
Subarea A:	0
Subarea B:	282
Minimum Off-Street Parking Spaces:	
Subarea A:	0
Subarea B:	89
Minimum Bike Parking Spaces	
Subarea A:	0
Subarea B:	153
Minimum Off-Street Loading Berths:	
Subarea A:	0
Subarea B:	2 (10' x 25')
Maximum Building Height:	
Subarea A:	Existing to remain

Applicant: 160 N. Morgan, LLC  
Address: 160 N Morgan / 180 N Morgan, Chicago, IL 60607  
Introduced: February 24, 2021  
Plan Commission: September 16, 2021

EAST\179043386 6

# FINAL FOR PUBLICATION

Subarea B: 350'0"     In accordance with plans  
Minimum Setbacks.

Applicant     160 N. Morgan, LLC  
Address     160 N Morgan / 180 N Morgan, Chicago, IL 60607  
Introduced     February 24, 2021  
Plan Commission.     September 16, 2021

EAST\179043386.6



EXISTING ZONING MAP  
Scale: N.T.S.



 Subject Property

 Property Line

**FINAL FOR  
PUBLICATION**

APPLICANT: 160 N MORGAN, LLC  
 ADDRESS: 160 N MORGAN/ 180 N MORGAN, CHICAGO, IL 60607  
 DATE OF INTRODUCTION: February 24, 2021  
 DATE OF PLAN COMMISSION: September 16, 2021



© 2021 b|KL Architecture LLC



GENERAL LAND-USE MAP  
Scale: N.T.S.



 Subject Property

 Property Line

**FINAL FOR  
PUBLICATION**

APPLICANT: 160 N MORGAN, LLC  
 ADDRESS: 160 N MORGAN/ 180 N MORGAN, CHICAGO, IL 60607  
 DATE OF INTRODUCTION: February 24, 2021  
 DATE OF PLAN COMMISSION: September 16, 2021



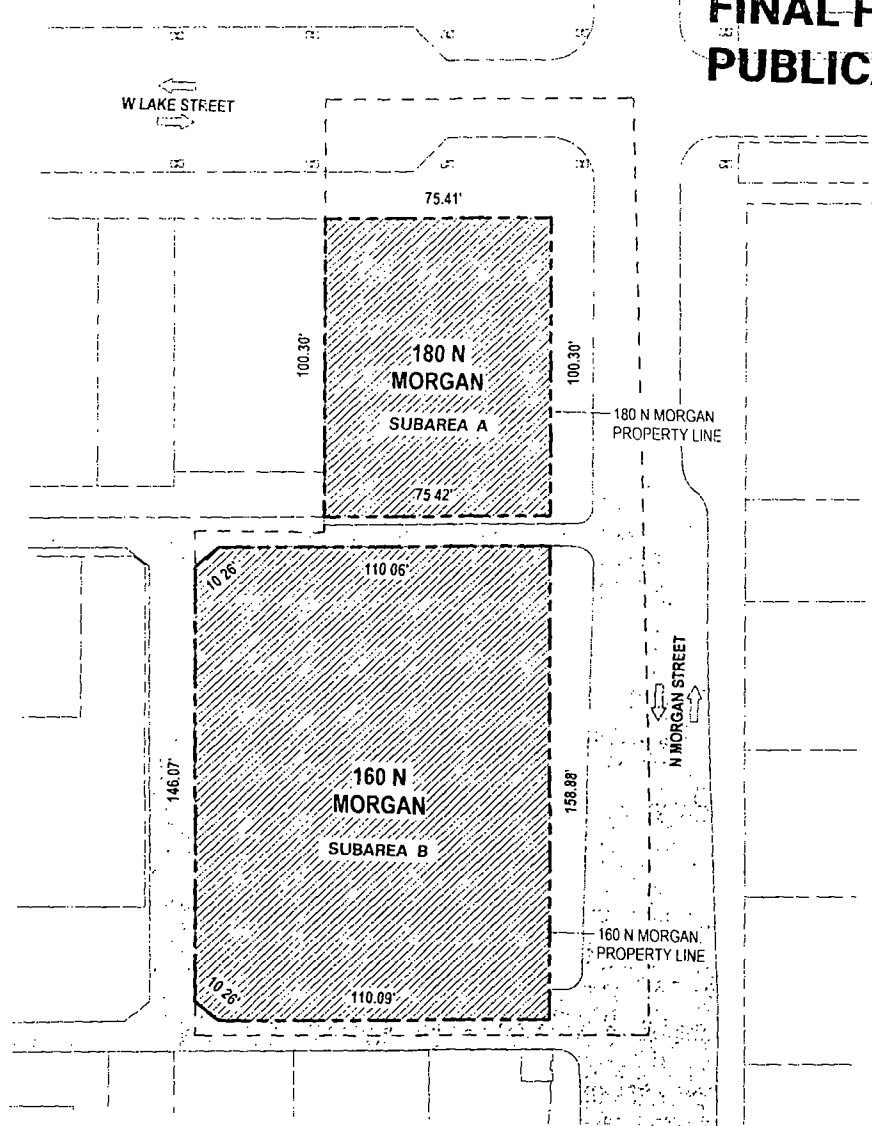

© 2021 b|KL Architects LLC

**FINAL FOR  
PUBLICATION**



PROPERTY LINE MAP  
Scale: N.T.S.



-  Subject Property
-  Property Line
-  PD Boundary

APPLICANT: 160 N MORGAN, LLC  
ADDRESS: 160 N MORGAN/ 180 N MORGAN, CHICAGO, IL 60607  
DATE OF INTRODUCTION: February 24, 2021  
DATE OF PLAN COMMISSION: September 16, 2021



© 2021 bkl Architecture LLC

# FINAL FOR PUBLICATION

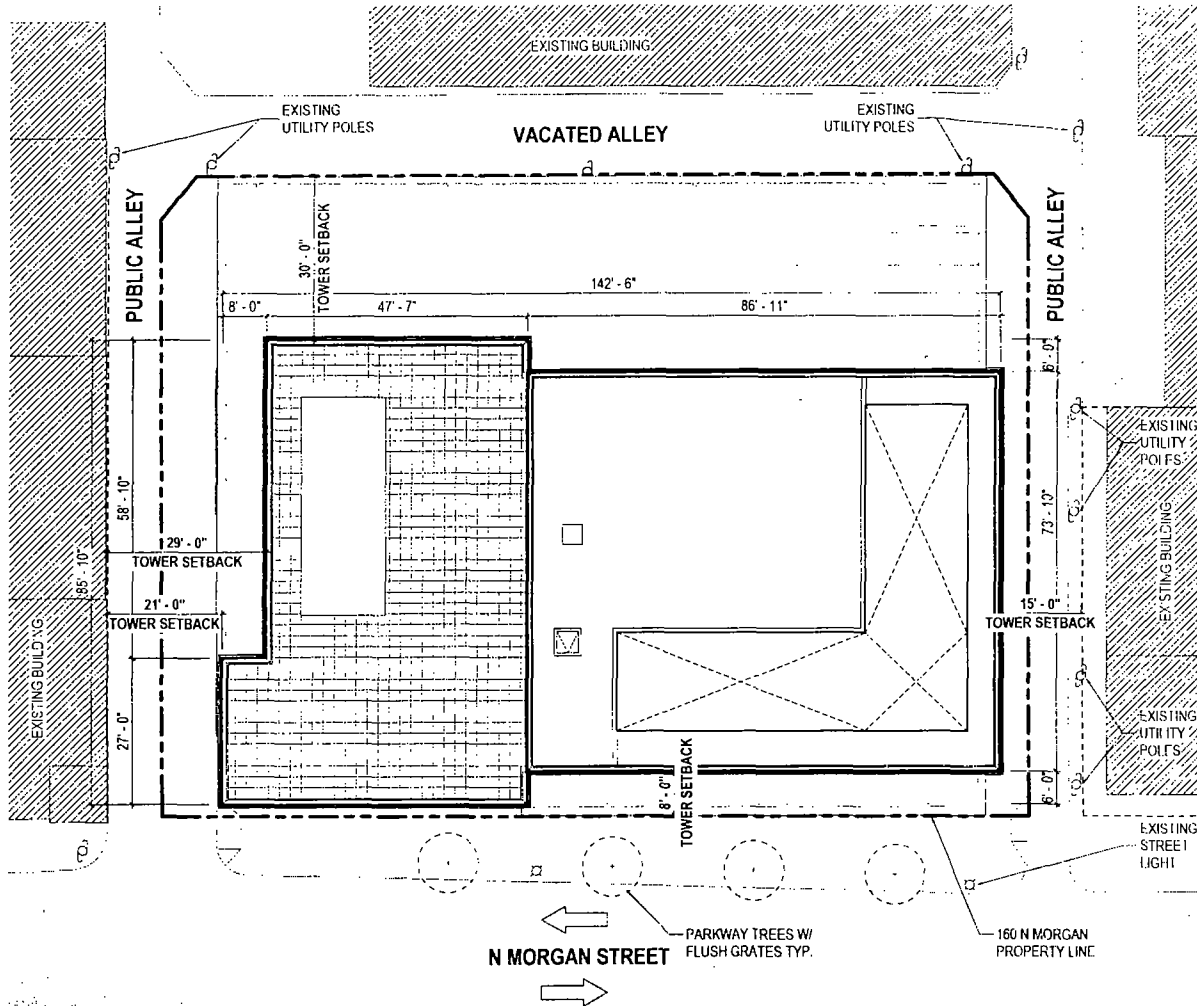

SITE PLAN  
Scale: N.T.S.



APPLICANT: 160 N MORGAN, LLC  
 ADDRESS: 160 N MORGAN/ 180 N MORGAN, CHICAGO, IL 60607  
 DATE OF INTRODUCTION: February 24, 2021  
 DATE OF PLAN COMMISSION: September 16, 2021



© 2021 bKL Architecture LLC

# FINAL FOR PUBLICATION

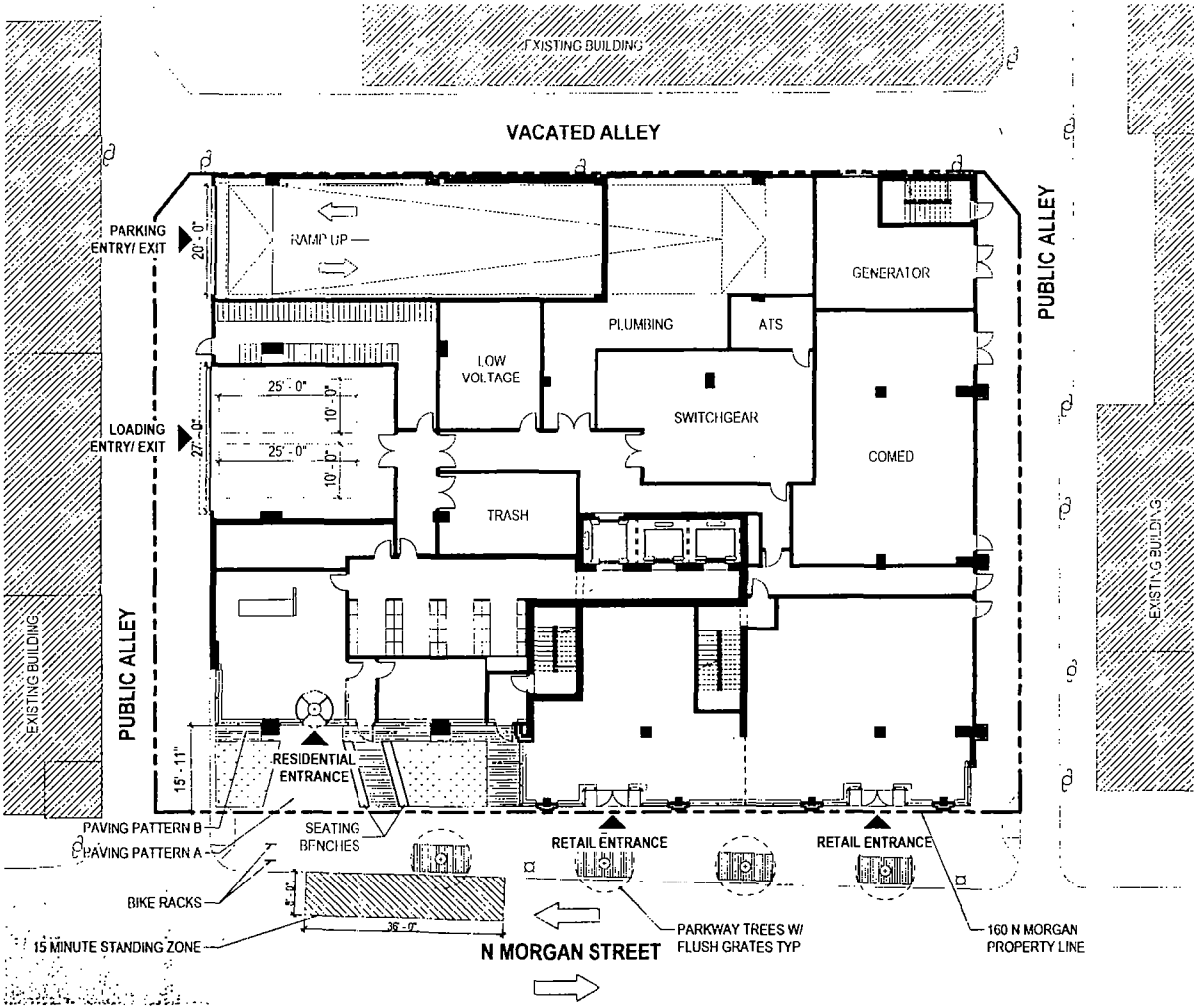

GROUND LEVEL PLAN  
Scale: N.T.S.



APPLICANT: 160 N MORGAN, LLC  
 ADDRESS: 160 N MORGAN/ 180 N MORGAN, CHICAGO, IL 60607  
 DATE OF INTRODUCTION: February 24, 2021  
 DATE OF PLAN COMMISSION: September 16, 2021



© 2021 bKL Architecture LLC

# FINAL FOR PUBLICATION

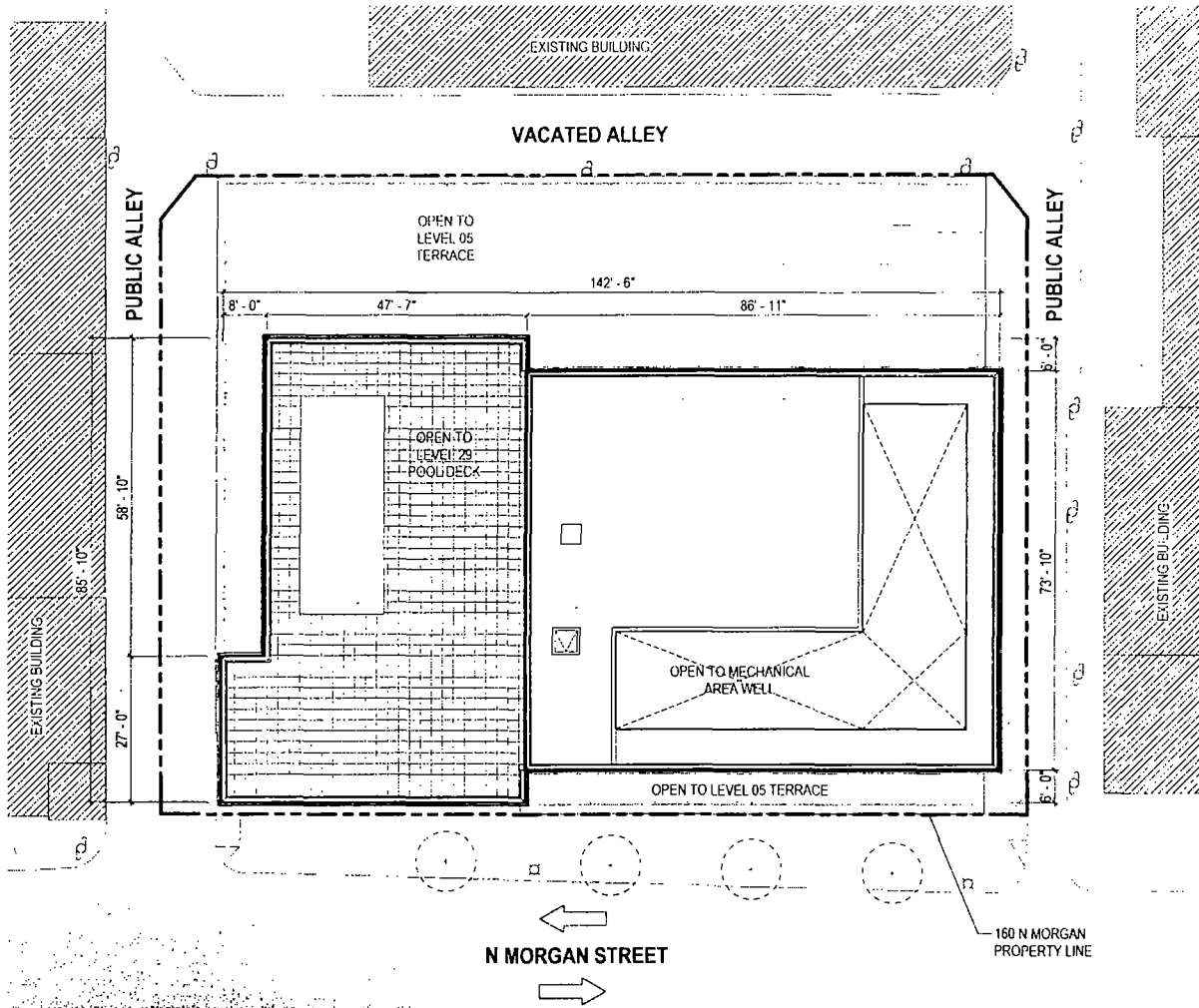

ROOF PLAN  
Scale: N.T.S.



APPLICANT: 160 N MORGAN, LLC  
 ADDRESS: 160 N MORGAN/ 180 N MORGAN, CHICAGO, IL 60607  
 DATE OF INTRODUCTION: February 24, 2021  
 DATE OF PLAN COMMISSION: September 16, 2021



© 2021 bKL Architecture LLC



# FINAL FOR PUBLICATION

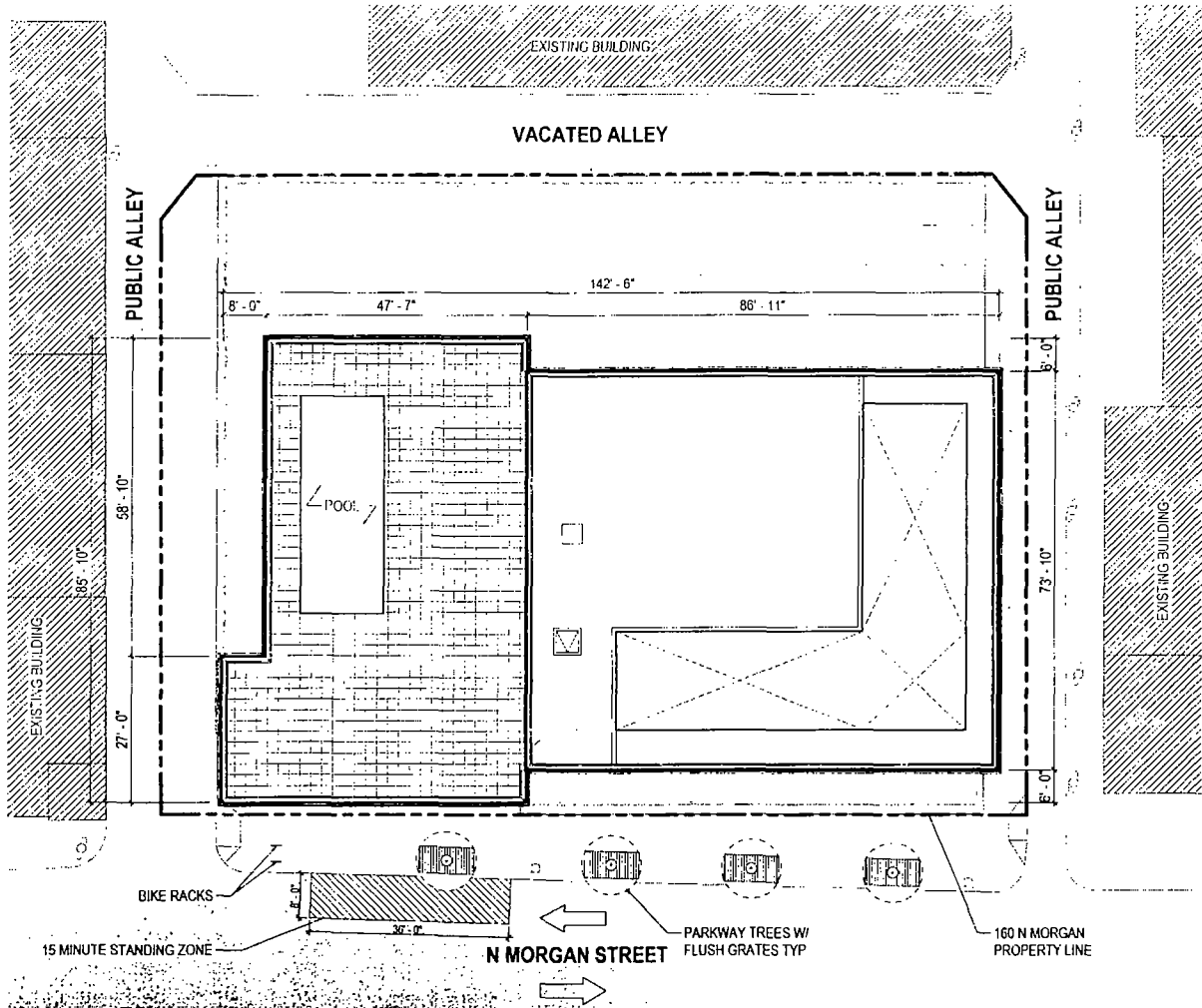

LANDSCAPE PLAN  
Scale: N.T.S.



APPLICANT: 160 N MORGAN, LLC  
 ADDRESS: 160 N MORGAN/ 180 N MORGAN, CHICAGO, IL 60607  
 DATE OF INTRODUCTION: February 24, 2021  
 DATE OF PLAN COMMISSION: September 16, 2021



© 2021 bKL Architecture LLC

# FINAL FOR PUBLICATION

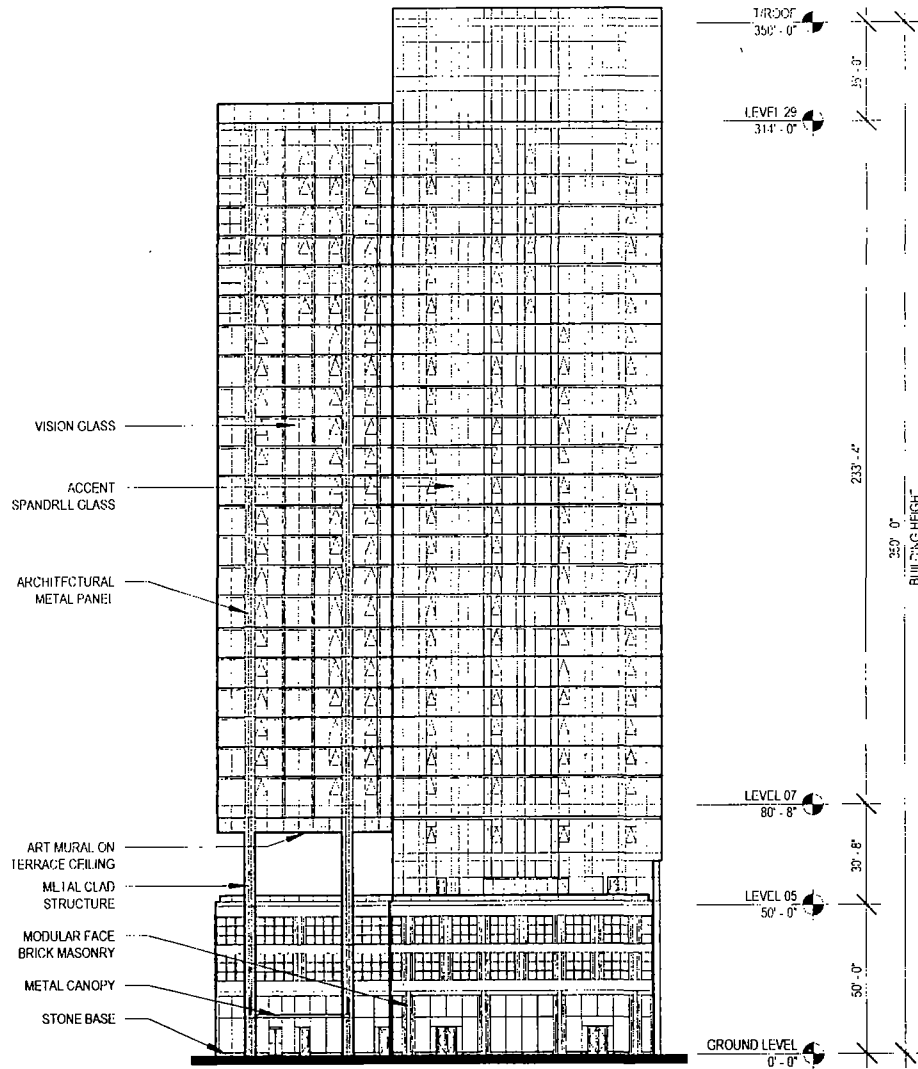

EAST BUILDING ELEVATION  
Scale: 1" = 50'-0"

APPLICANT: 160 N MORGAN, LLC  
 ADDRESS: 160 N MORGAN/ 180 N MORGAN, CHICAGO, IL 60607  
 DATE OF INTRODUCTION: February 24, 2021  
 DATE OF PLAN COMMISSION: September 16, 2021

# FINAL FOR PUBLICATION

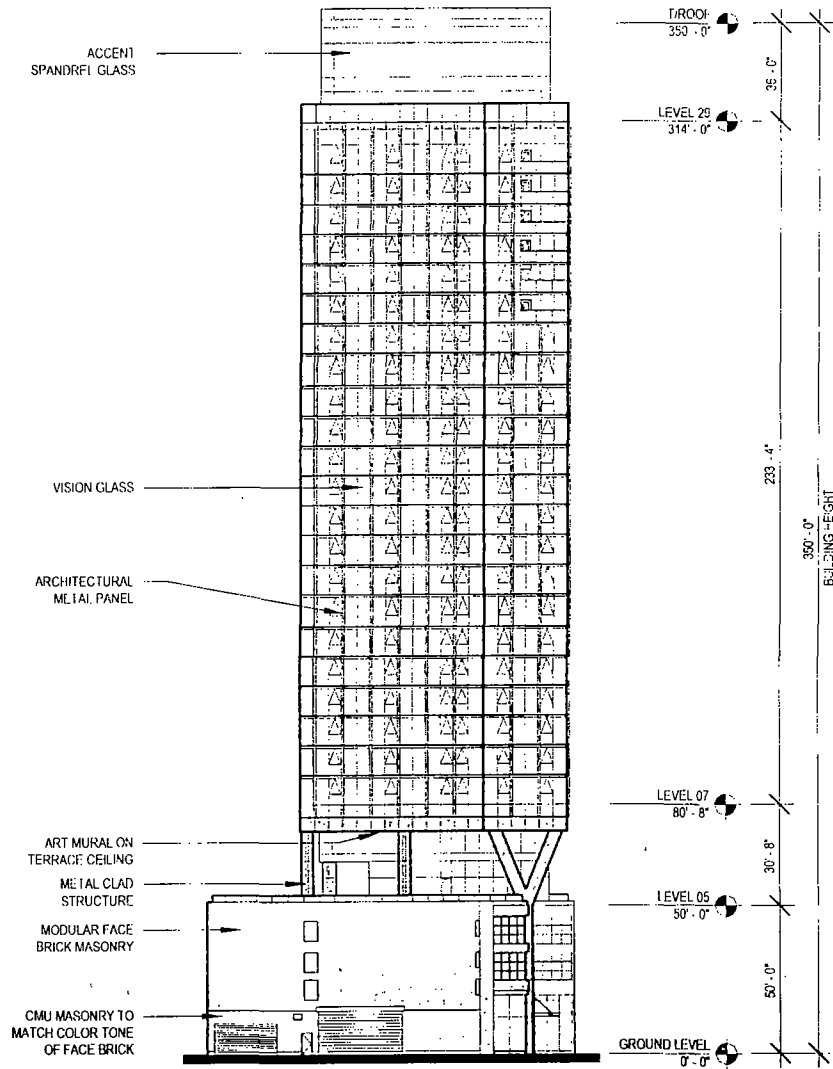

SOUTH BUILDING ELEVATION  
Scale: 1" = 50'-0"

APPLICANT 160 N MORGAN, LLC  
 ADDRESS. 160 N MORGAN/ 180 N MORGAN, CHICAGO, IL 60607  
 DATE OF INTRODUCTION: February 24, 2021  
 DATE OF PLAN COMMISSION: September 16, 2021



© 2021 bKL Architecture LLC

# FINAL FOR PUBLICATION

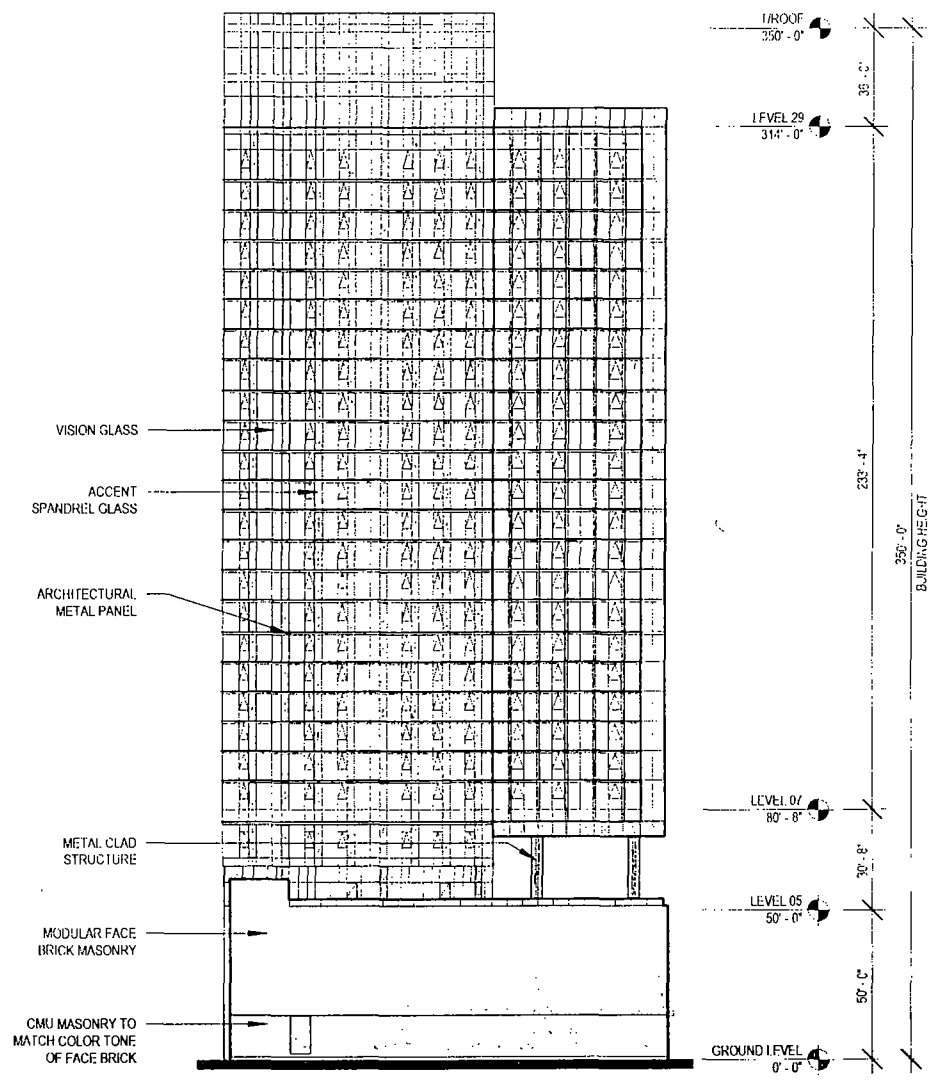

## WEST BUILDING ELEVATION

Scale: 1" = 50'-0"

APPLICANT: 160 N MORGAN, LLC  
ADDRESS 160 N MORGAN/ 180 N MORGAN, CHICAGO, IL 60607  
DATE OF INTRODUCTION: February 24, 2021  
DATE OF PLAN COMMISSION: September 16, 2021



© 2021 b KL Architecture LLC

# FINAL FOR PUBLICATION

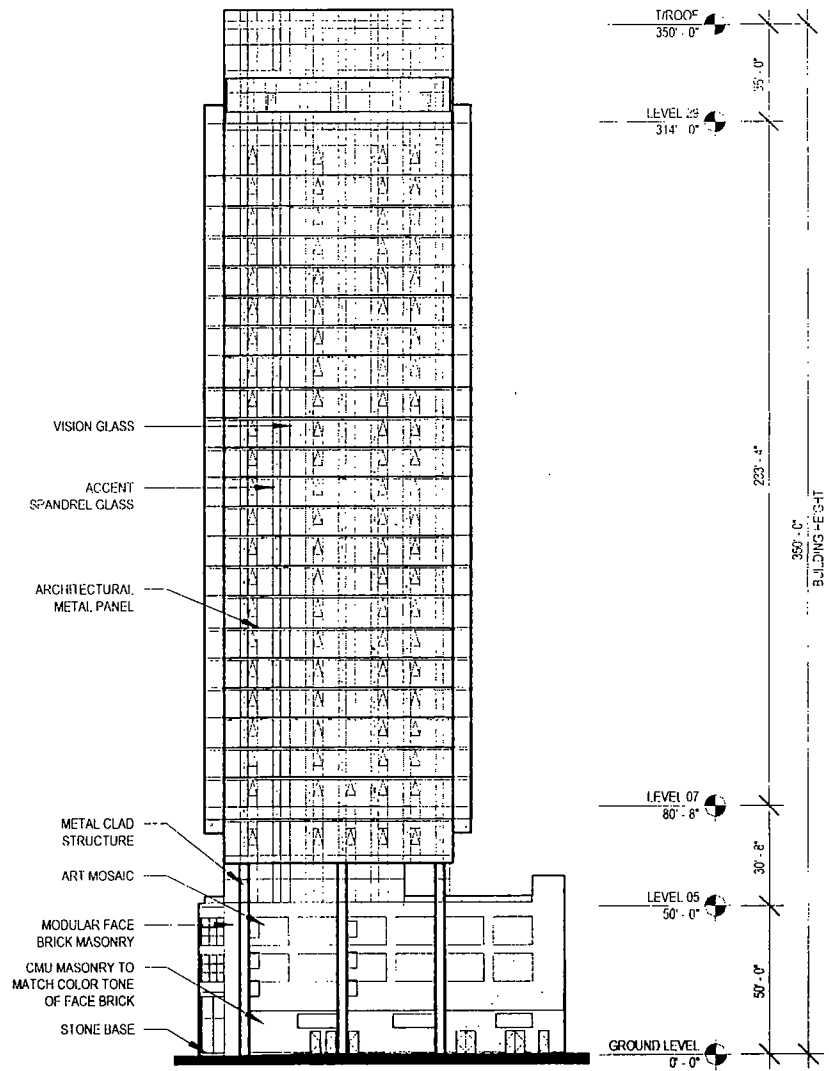

NORTH BUILDING ELEVATION  
 Scale: 1" = 50'-0"

APPLICANT: 160 N MORGAN, LLC  
 ADDRESS: 160 N MORGAN/ 180 N MORGAN, CHICAGO, IL 60607  
 DATE OF INTRODUCTION: February 24, 2021  
 DATE OF PLAN COMMISSION: September 16, 2021



# FINAL FOR PUBLICATION

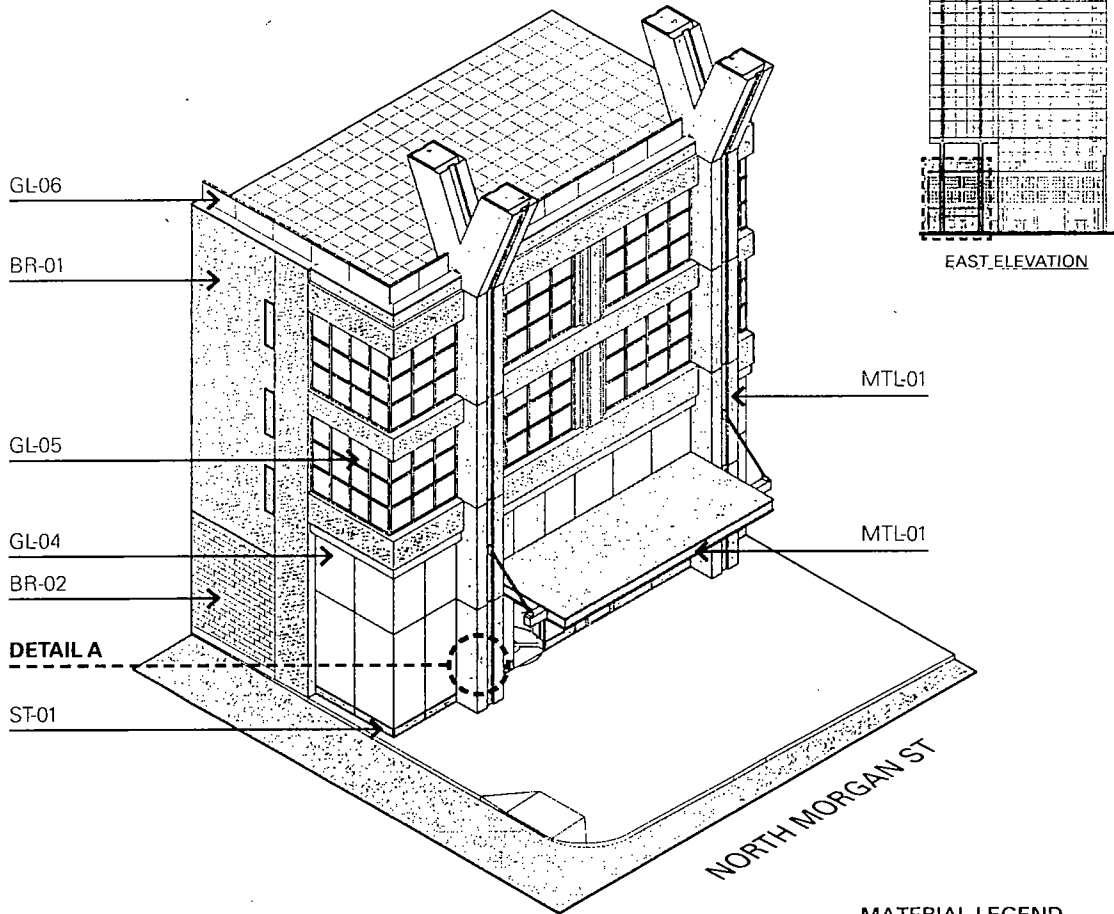

BUILDING BASE AXONOMETRIC VIEW - SOUTHEAST CORNER

## MATERIAL LEGEND

GL-01	VISION GLASS
GL-02	SPANDREL GLASS
GL-03	ACCENT SPANDREL GLASS
GL-04	ULTRA CLEAR VISION GLASS
GL-05	TRANSLUCENT GLASS
GL-06	LAMINATED VISION GLASS
MTL-01	PAINTED ALUMINUM
BR-01	STANDARD MODULAR BRICK
BR-02	BURNISHED CMU BLOCK
ST-01	STONE BASE

APPLICANT: 160 N MORGAN, LLC  
 ADDRESS: 160 N MORGAN/ 180 N MORGAN, CHICAGO, IL 60607  
 DATE OF INTRODUCTION: February 24, 2021  
 DATE OF PLAN COMMISSION: September 16, 2021



© 2021 b|KL Architecture | LC

# FINAL FOR PUBLICATION

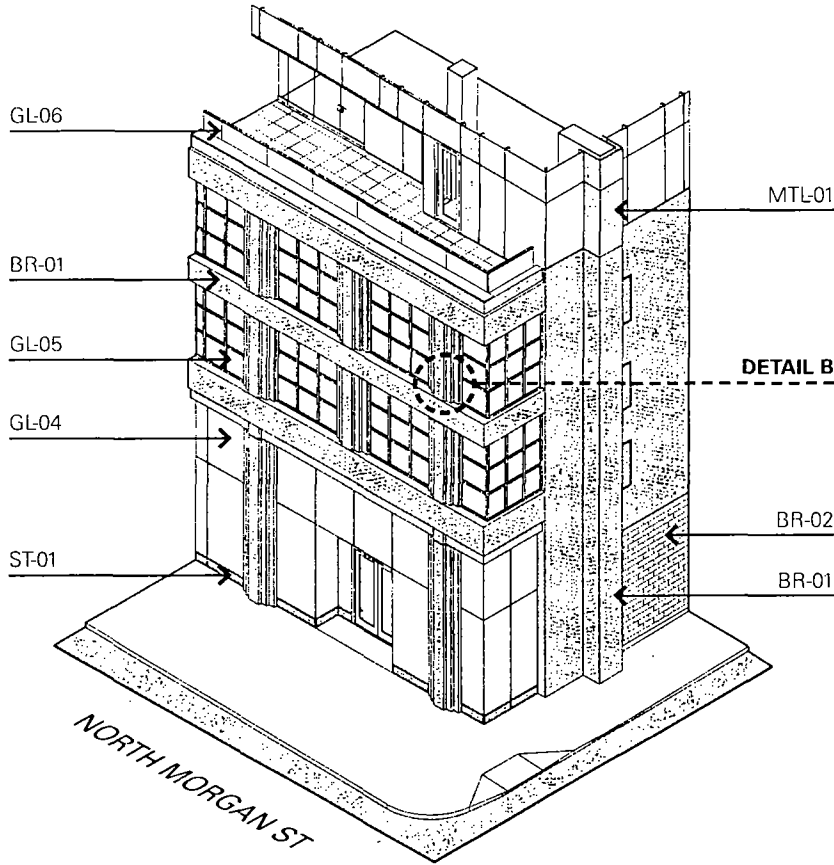
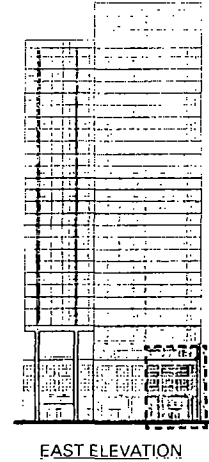

## MATERIAL LEGEND

GL-01	VISION GLASS
GL-02	SPANDREL GLASS
GL-03	ACCENT SPANDREL GLASS
GL-04	ULTRA CLEAR VISION GLASS
GL-05	TRANSLUCENT GLASS
GL-06	LAMINATED VISION GLASS
MTL-01	PAINTED ALUMINUM
BR-01	STANDARD MODULAR BRICK
BR-02	BURNISHED CMU BLOCK
ST-01	STONE BASE

BUILDING BASE AXONOMETRIC VIEW - NORTHEAST CORNER

APPLICANT: 160 N MORGAN, LLC  
 ADDRESS: 160 N MORGAN/ 180 N MORGAN, CHICAGO, IL 60607  
 DATE OF INTRODUCTION: February 24, 2021  
 DATE OF PLAN COMMISSION: September 16, 2021



© 2021 b|KL Architecture LLC

# FINAL FOR PUBLICATION

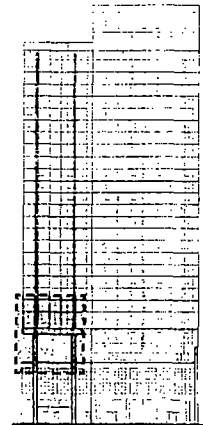

EAST ELEVATION

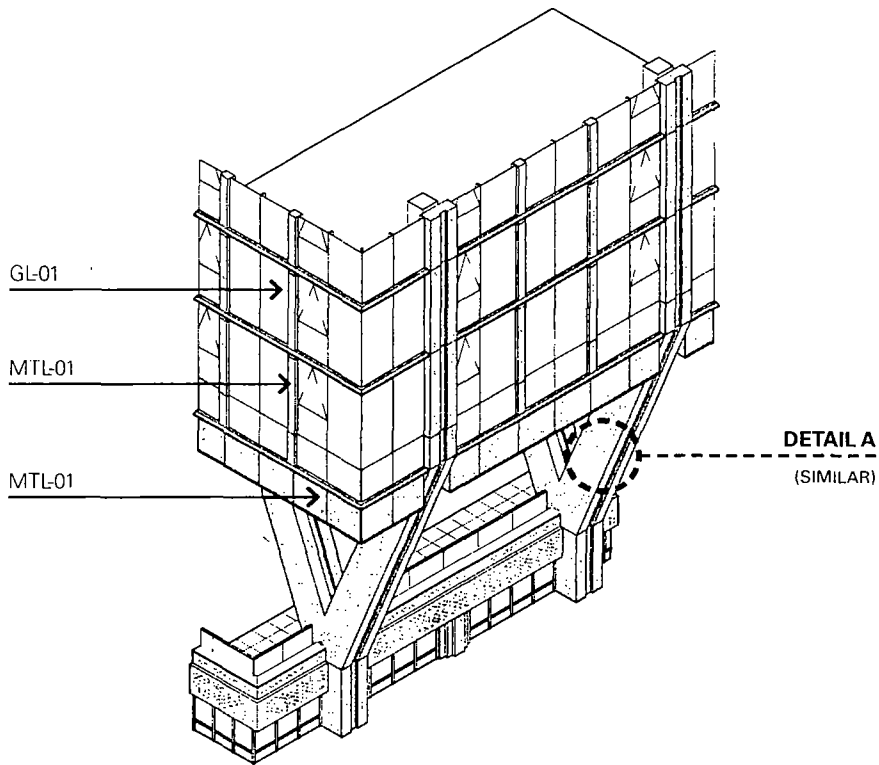

LEVEL 05 TERRACE AXONOMETRIC VIEW - SOUTHEAST CORNER

## MATERIAL LEGEND

GL-01	VISION GLASS
GL-02	SPANDREL GLASS
GL-03	ACCENT SPANDREL GLASS
GL-04	ULTRA CLEAR VISION GLASS
GL-05	TRANSLUCENT GLASS
GL-06	LAMINATED VISION GLASS
MTL-01	PAINTED ALUMINUM
BR-01	STANDARD MODULAR BRICK
BR-02	BURNISHED CMU BLOCK
ST-01	STONE BASE

APPLICANT: 160 N MORGAN, LLC  
 ADDRESS: 160 N MORGAN/ 180 N MORGAN, CHICAGO, IL 60607  
 DATE OF INTRODUCTION: February 24, 2021  
 DATE OF PLAN COMMISSION: September 16, 2021



© 2021 bKL Architecture LLC



# FINAL FOR PUBLICATION

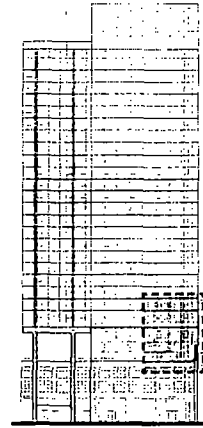

EAST ELEVATION

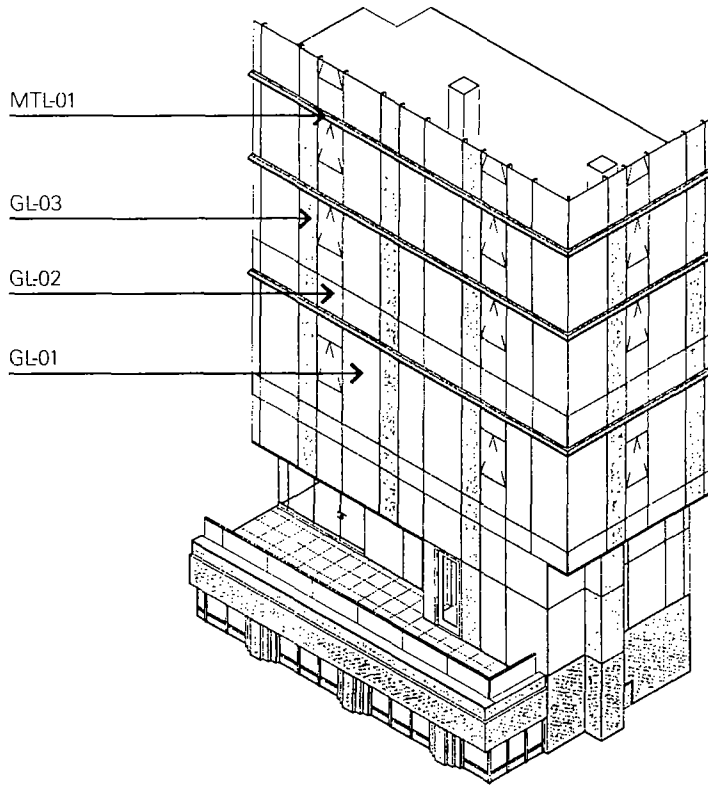

LEVEL 05 TERRACE AXONOMETRIC VIEW - NORTHEAST CORNER

## MATERIAL LEGEND

GL-01	VISION GLASS
GL-02	SPANDREL GLASS
GL-03	ACCENT SPANDREL GLASS
GL-04	ULTRA CLEAR VISION GLASS
GL-05	TRANSLUCENT GLASS
GL-06	LAMINATED VISION GLASS
MTL-01	PAINTED ALUMINUM
BR-01	STANDARD MODULAR BRICK
BR-02	BURNISHED CMU BLOCK
SI-01	STONE BASE

APPLICANT: 160 N MORGAN, LLC  
 ADDRESS: 160 N MORGAN/ 180 N MORGAN, CHICAGO, IL 60607  
 DATE OF INTRODUCTION: February 24, 2021  
 DATE OF PLAN COMMISSION: September 16, 2021



© 2021 bKL Architecture LLC

# FINAL FOR PUBLICATION

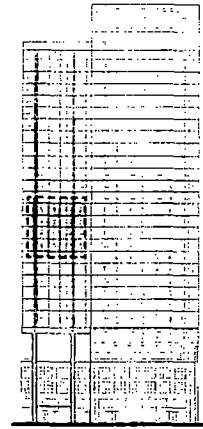

EAST ELEVATION

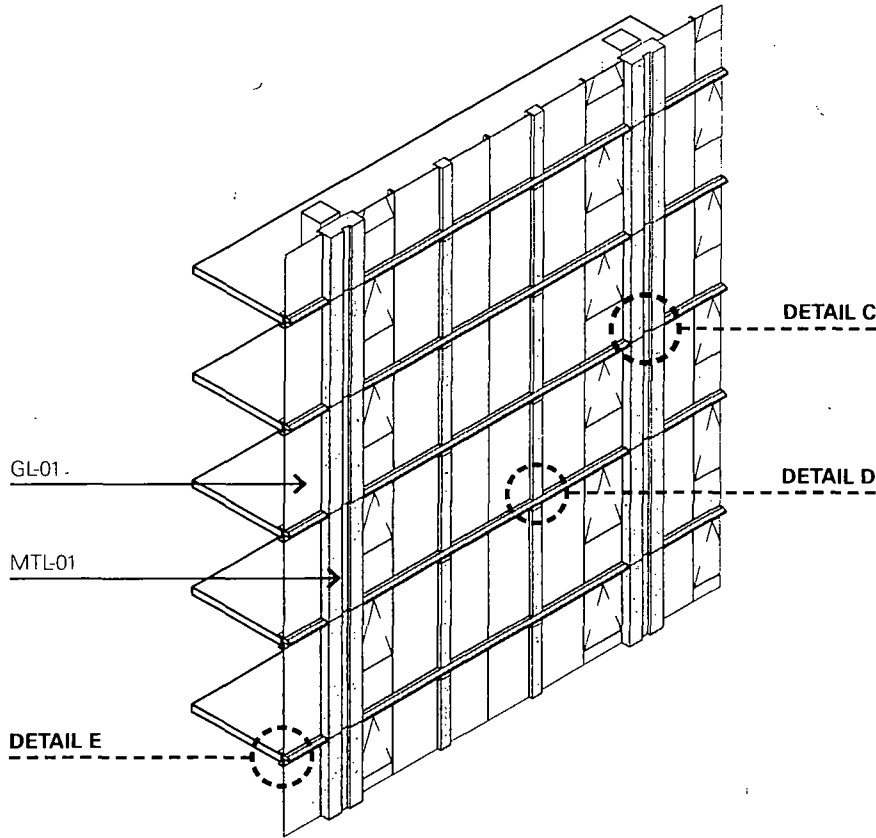

TYPICAL TOWER AXONOMETRIC VIEW - SOUTH BLOCK

### MATERIAL LEGEND

GL-01	VISION GLASS
GL-02	SPANDREL GLASS
GL-03	ACCENT SPANDREL GLASS
GL-04	ULTRA CLEAR VISION GLASS
GL-05	TRANSLUCENT GLASS
GL-06	LAMINATED VISION GLASS
MTL-01	PAINTED ALUMINUM
BR-01	STANDARD MODULAR BRICK
BR-02	BURNISHED CMU BLOCK
SF-01	STONE BASE

APPLICANT: 160 N MORGAN, LLC  
 ADDRESS: 160 N MORGAN/ 180 N MORGAN, CHICAGO, IL 60607  
 DATE OF INTRODUCTION: February 24, 2021  
 DATE OF PLAN COMMISSION: September 16, 2021



© 2021 bKL Architecture, LLC

# FINAL FOR PUBLICATION

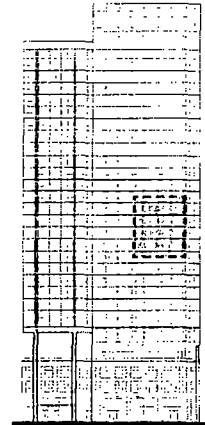

EAST ELEVATION

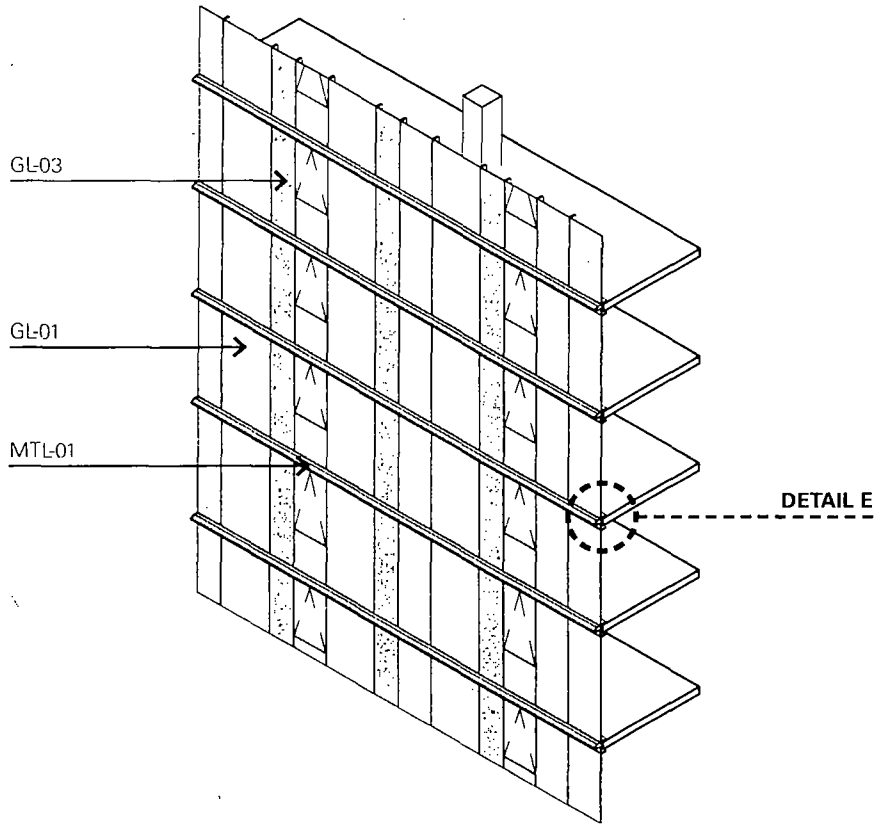

TYPICAL TOWER AXONOMETRIC VIEW - NORTH BLOCK

## MATERIAL LEGEND

GL-01	VISION GLASS
GL-02	SPANDREL GLASS
GL-03	ACCENT SPANDREL GLASS
GL-04	ULTRA CLEAR VISION GLASS
GL-05	TRANSLUCENT GLASS
GL-06	LAMINATED VISION GLASS
MTL-01	PAINTED ALUMINUM
BR-01	STANDARD MODULAR BRICK
BR-02	BURNISHED CMU BLOCK
ST-01	STONE BASE

APPLICANT: 160 N MORGAN, LLC  
 ADDRESS: 160 N MORGAN/ 180 N MORGAN, CHICAGO, IL 60607  
 DATE OF INTRODUCTION: February 24, 2021  
 DATE OF PLAN COMMISSION: September 16, 2021



© 2021 bKL Architecture LLC

# FINAL FOR PUBLICATION

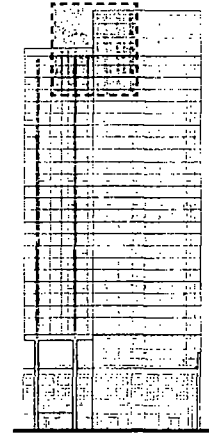

EAST ELEVATION

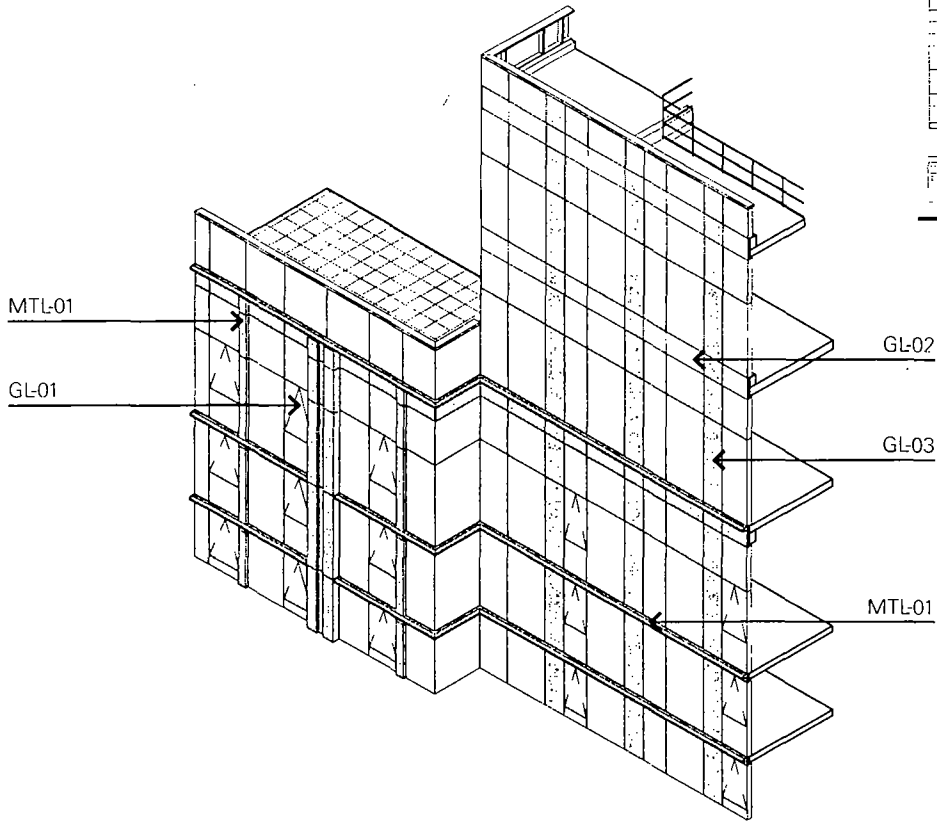

## MATERIAL LEGEND

GL-01	VISION GLASS
GL-02	SPANDREL GLASS
GL-03	ACCENT SPANDREL GLASS
GL-04	ULTRA CLEAR VISION GLASS
GL-05	TRANSLUCENT GLASS
GL-06	LAMINATED VISION GLASS
MTL-01	PAINTED ALUMINUM
BR-01	STANDARD MODULAR BRICK
BR-02	BURNISHED CMU BLOCK
ST-01	STONE BASE

BUILDING TOP AXONOMETRIC VIEW - EAST FACADE

APPLICANT: 160 N MORGAN, LLC  
 ADDRESS: 160 N MORGAN/ 180 N MORGAN, CHICAGO, IL 60607  
 DATE OF INTRODUCTION: February 24, 2021  
 DATE OF PLAN COMMISSION: September 16, 2021



© 2021 b|KL Architecture LLC

# FINAL FOR PUBLICATION

## FACADE DETAIL A

PLAN DETAIL - PODIUM METAL PANEL CLADDING AT COLUMN

Scale 3/4" = 1'-0"

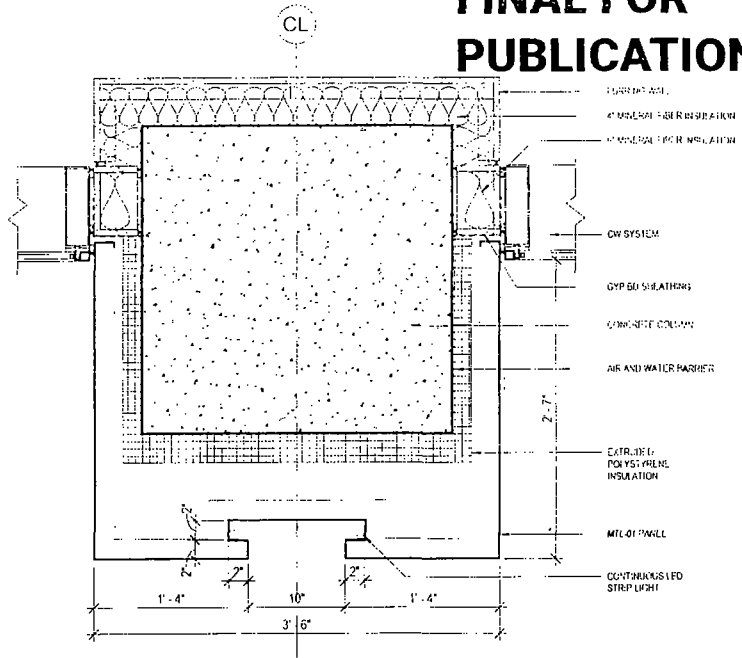

## FACADE DETAIL B

PLAN DETAIL - PODIUM BRICK MASONRY PIER

Scale: 3/4" = 1'-0"

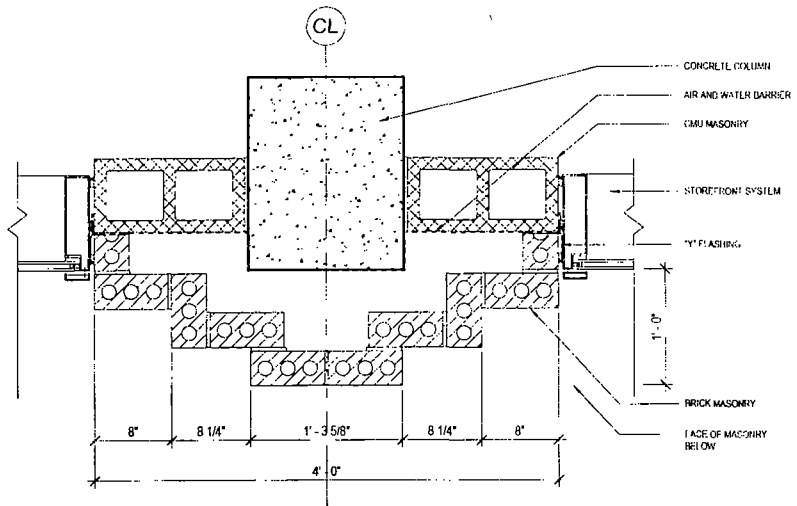

APPLICANT: 160 N MORGAN, LLC  
 ADDRESS: 160 N MORGAN/ 180 N MORGAN, CHICAGO, IL 60607  
 DATE OF INTRODUCTION: February 24, 2021  
 DATE OF PLAN COMMISSION: September 16, 2021



© 2021 bKL Architecture LLC

# FINAL FOR PUBLICATION

**FACADE DETAIL C**  
 PLAN DETAIL - TYPICAL  
 TOWER METAL PANEL  
 PROFILE

Scale: 3/4" = 1'-0"

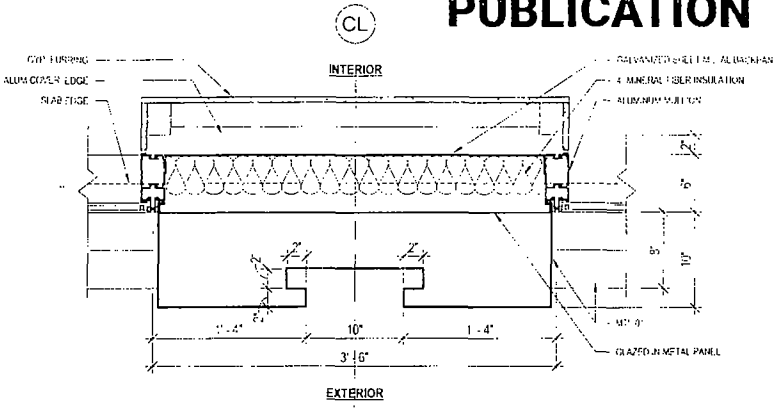

**FACADE DETAIL D**  
 PLAN DETAIL - TYPICAL  
 TOWER METAL PANEL  
 PROFILE

Scale: 3/4" = 1'-0"

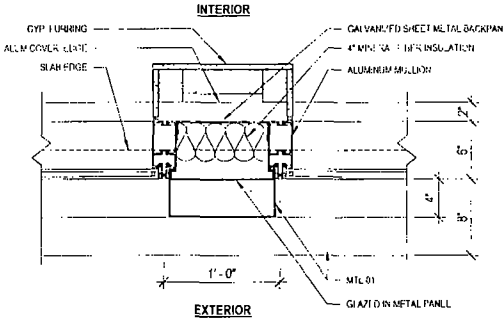

**FACADE DETAIL E**  
 SECTION DETAIL - TYPICAL  
 TOWER METAL PANEL SLAB  
 EDGE PROFILE

Scale: 3/4" = 1'-0"

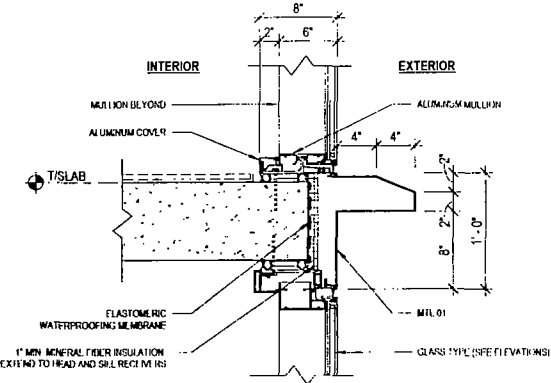

APPLICANT: 160 N MORGAN, LLC  
 ADDRESS: 160 N MORGAN/ 180 N MORGAN, CHICAGO, IL 60607  
 DATE OF INTRODUCTION: February 24, 2021  
 DATE OF PLAN COMMISSION: September 16, 2021



© 2021 bKL Architecture LLC

## ARO Affordable Housing Profile Form (AHP)

Submit this form for projects that are subject to the 2015 ARO (all projects submitted to City Council after October 13, 2015). More information is online at [www.cityofchicago.org/ARO](http://www.cityofchicago.org/ARO).

This completed form should be returned to the Department of Housing (DOH), 121 N LaSalle Street, 10th Floor, Chicago, IL 60602. E-mail: [ARO@cityofchicago.org](mailto:ARO@cityofchicago.org)

Date: 08/20/2021

### DEVELOPMENT INFORMATION

Development Name: 160 N Morgan

Development Address: 160 N Morgan St, Chicago, IL 60607

Zoning Application Number, if applicable: N/A

If you are working with a Planner at the City, what is his/her name?

Ward: 27

Joshua Son

### Type of City Involvement

check all that apply

City Land

Financial Assistance

Zoning increase.

Planned Development (PD)

Transit Served Location (TSL) project

# FINAL FOR PUBLICATION

**REQUIRED ATTACHMENTS:** the AHP will not be reviewed until all required docs are received

- ARO Web Form completed and attached - or submitted online on
- ARO "Affordable Unit Details and Square Footage" worksheet completed and attached (*Excel*)
- If ARO units proposed, Dimensioned Floor Plans with affordable units highlighted are attached (*pdf*)
- If ARO units proposed are off-site, required attachments are included (see next page)
- If ARO units are CHA/Authorized Agency units, signed acceptance letter is attached (*pdf*)

### DEVELOPER INFORMATION

Developer Name Sterling Bay

Developer Contact Brian Bezanis

Developer Address 333 N Green, Chicago, IL 60607

Email [bbezanis@sterlingbay.com](mailto:bbezanis@sterlingbay.com)

Developer Phone 312-566-4937

Attorney Name Katie Jahnke Dale

Attorney Phone 312-368-2153

### TIMING

Estimated date marketing will begin Q2 2023

Estimated date of building permit\* 01/15/2022

Estimated date ARO units will be complete Q1 2024

\*the in-lieu fee, recorded covenant and \$5,000 per unit administration fee (for off-site units) are required prior to the issuance of any building permits, including the foundation permit.

**PROPOSED UNITS MEET REQUIREMENTS** (to be executed by Developer & ARO Project Manager)

Developer or their agent

Date

9/14/2021

ARO Project Manager

Date

9/15/2021



AFFORDABLE REQUIREMENTS ORDINANCE

Last updated January 11, 2019

**FINAL FOR  
PUBLICATION**

**ARO Intake Form**

**Applicant Contact Information:**

**Name:** 160 N. Morgan, LLC      **Email:** [bbezanis@sterlingbay.com](mailto:bbezanis@sterlingbay.com)      **Phone:** 312-566-4937

**Development Information:**

**Triggering Project Address**  
**Number:** 160      **Direction:** North      **Street Name:** Morgan Street      **Postal Code:** 60607

**Development Name:** 160 N Morgan

**Are you rezoning to downtown?** Yes

**Ward:** 27      **ARO Area:** Inclusionary Housing Area

**ARO Trigger:** Zoning change and planned development      **Total Units:** 282      **Development Type:** Rental

**Requirements:**

**How do you intend to meet your ARO obligation?**

**On-site:** 28      **Off-Site:** 28.4

**Total Units:**  
56.4

**Off-Site ARO Unit Information:**

**Will the Off-Site Units be Rental or For-Sale?** Rental

**Address:**

**Number:** 2548      **Direction:** South      **Street Name:** Federal Street      **Postal Code:** 60616

**ARO Area:** Inclusionary Housing Area      **Ward:** 3      **Distance from Triggering Project:** 2.9 Miles      **Off-Site Administrative Fee\*** \$140,000

\*Please note that an administrative fee of \$5,000 per off-site unit must be received by the ARO Project Manager in addition to any in-lieu fees owed - prior to the issuance of any building permits for the project, including, without limitation, excavation, or foundation permits.



# FINAL FOR PUBLICATION

Project Name	160 N Morgan
Zoning Application number, if applicable	
Address	160 N Morgan Street, Chicago, IL, 60607
Is this a For Sale or Rental Project?	Rental Project
If a For Sale Project, will you offer ARO	n/a
Anticipated average psf rent/price?*	\$4.00 psf

Total Units in Project	282		
First Units (10% of total)	28	Will First Units be on-site or off-site?	on-site If off-site, what is address? 160 N Morgan Street, Chicago, IL, 60607
Additional Units (20% of total, less number of "First Units")	28	Will Additional Units be on-site or off-site?	off-site If off-site, what is address? 2548 S Federal Street, Chicago, IL, 60616

### Summary

unit type	market rate			ARO On-site Units				ARO Off-site Units			
	how many?	% of total	avg. square footage	how many?*	% of total	avg. square footage	affordable v. market square footage*	how many?*	% of total	avg. square footage	affordable v. market square footage*
studio	132	52.0%	584	14	50.0%	554	95%				
one-bed	77	30.3%	760	9	32.1%	760	100%				
two-bed	40	15.7%	1,183	4	14.3%	1,208	102%	28.4	100.0%	850	72%
three-bed	5	2.0%	1,669	1	3.6%	1,669	100%				

This is a preliminarily approved AHP, which will be revised when further project details are determined. The Applicant is electing option 1 under subsection (F)(2) of 2-44-085 (the "ARO"), and has agreed to provide a weighted average of 60% AMI in accordance with the income level standards described in the ARO Rules.

# FINAL FOR PUBLICATION

Completed by/Developer			
Onsite Project Name and address 160 N Morgan, Chicago, IL			
Off-Site Project Address. 2548 S Federal Street, Chicago, IL			
ARO/HOUSING CRITERIA	ON SITE		OFF SITE
	MARKET RATE	AFFORDABLE	AFFORDABLE
<b>1.0 Site Improvements</b>			
Surrounding/Site Conditions			
Sod, Plantings or Hardscape	Parkway trees, landscape plantings at terraces		Landscape plantings
Parking	Exterior	0	0
	Interior	89	89
Security			tbd
<b>2.0 Building Architectural &amp; Structural Systems</b>			
Building Envelope			
Roof	Modified Bitumen		tbd
Exterior Walls	Window Wall (tower) and Masonry (podium)		Masonry & Curtainwall
Exterior Door & Windows	Aluminum and glass		Aluminum and glass
Foundations	Cast-in-place		existing
Common Facilities			
Laundry Facilities	Laundry in each unit		Laundry in each unit
Bulk Storage (Ln Ft)			tbd
Maintenance			tbd
Commercial Amenities	2800 sf retail		n/a
Recreational Amenities	Pool, Fitness, Lounge, Outdoor Terraces		Roof Terraces
Accessibility			
<b>3.0 Building Mechanical, Electrical, &amp; Plumbing Systems</b>			
HVAC	Heat pumps, cooling towers		heat pumps
Plumbing			low flow fixtures
Electrical			
Conveying System			
Elevator	3 residential elevators		2 elevators
Sustainability Certifications	Green Globes 2 Globes Certification		TBD
Green Roof	No		Yes
Sustainable Features	High performance glass		Solar panels, PHUS tbd
<b>4.0 Interiors</b>			
Unit Type - 3 Bedroom			TBD
Square Footage	1669	1669	
Bathroom Count	3	3	
Unit Type - 2 Bedroom			TBD
Square Footage	1183	1183	
Bathroom Count	2	2	
Unit Type - 1 Bedroom			
Square Footage	760	760	
Bathroom Count	1	1	
Unit Type - Studio			
Square Footage	584	584	
Bathroom Count	1	1	
Kitchens			
Linear Feet of Work Space	9	9	
Cabinet (Cubic Ft)	80	80	
Countertop Material	Stone	Stone	
Square Footage	90	90	
Wall Finish	Paint	Paint	
Floor Finish	Vinyl plank	Vinyl plank	
Appliances			
Stove/Range	Stainless Steel	Stainless Steel	Stainless
Microwave	Stainless Steel	Stainless Steel	Stainless
Refrigerator	Stainless Steel	Stainless Steel	Stainless
Dishwasher	Stainless Steel	Stainless Steel	Stainless
ARO/HOUSING CRITERIA	ON SITE MARKET RATE	ON SITE AFFORDABLE	OFF SITE AFFORDABLE
In Unit Bulk Storage			
Cubic Feet			
Living Room			tbd

# FINAL FOR PUBLICATION

	<i>Square Footage</i>	175	175	
	<i>Wall Finish</i>	Paint	Paint	
	<i>Floor Finish</i>	Vinyl Plank	Vinyl Plank	
Dining Room				tbd
	<i>Square Footage</i>			
	<i>Wall Finish</i>			
	<i>Floor Finish</i>			
Bedroom #1				tbd
	<i>Square Footage</i>	110	110	
	<i>Wall Finish</i>	Paint	Paint	
	<i>Floor Finish</i>	Vinyl Plank	Vinyl Plank	
	<i>Closet/Storage (Ln )</i>	7'	7'	
Bedroom #2				tbd
	<i>Square Footage</i>	105	105	
	<i>Wall Finish</i>	Paint	Paint	
	<i>Floor Finish</i>	Vinyl Plank	Vinyl Plank	
	<i>Closet/Storage (Ln )</i>	7'	7'	
Bedroom #3				tbd
	<i>Square Footage</i>	105	105	
	<i>Wall Finish</i>	Paint	Paint	
	<i>Floor Finish</i>	Vinyl Plank	Vinyl Plank	
	<i>Closet/Storage (Ln )</i>	7'	7'	
Bedroom #4/Other				tbd
	<i>Square Footage</i>			
	<i>Wall Finish</i>			
	<i>Floor Finish</i>			
	<i>Closet/Storage (Ln )</i>			
Laundry	<i>Washer</i>	White	White	tbd
	<i>Dryer</i>	White	White	tbd
Bathroom #1				tbd
	<i>Square Footage</i>	65	65	
	<i>Wall Finish</i>	Paint/Tile	Paint/Tile	
	<i>Floor Finish</i>	Tile	Tile	
	<i>Fixtures</i>	Toilet, Vanity, Tub or Shower	Toilet, Vanity, Tub or Shower	
Bathroom #2				tbd
	<i>Square Footage</i>	65	65	
	<i>Wall Finish</i>	Paint/Tile	Paint/Tile	
	<i>Floor Finish</i>	Tile	Tile	
	<i>Fixtures</i>	Toilet, Vanity, Tub or Shower	Toilet, Vanity, Tub or Shower	
Bathroom ½ or ¾ Bath				tbd
	<i>Square Footage</i>			
	<i>Wall Finish</i>			
	<i>Floor Finish</i>			
	<i>Fixtures</i>			
<b>5.0 Other Structures</b>				
Garage, Canopy, Gazebo, Playlot, Storage Shed		Parking garage, canopy		n/a
<b>6.0 Environmental Issues</b>				
ACM , IBP, Mold, Radon, Pest Control, Storage Tanks				

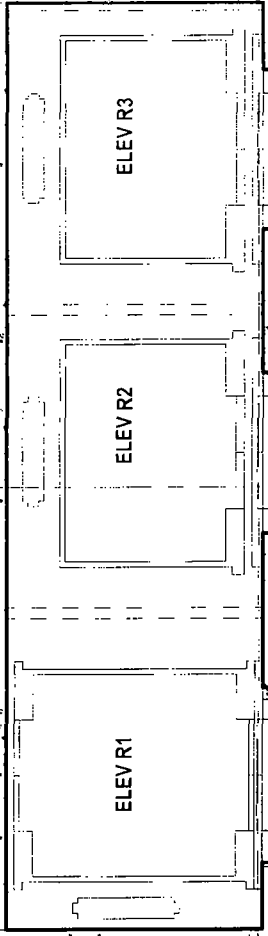
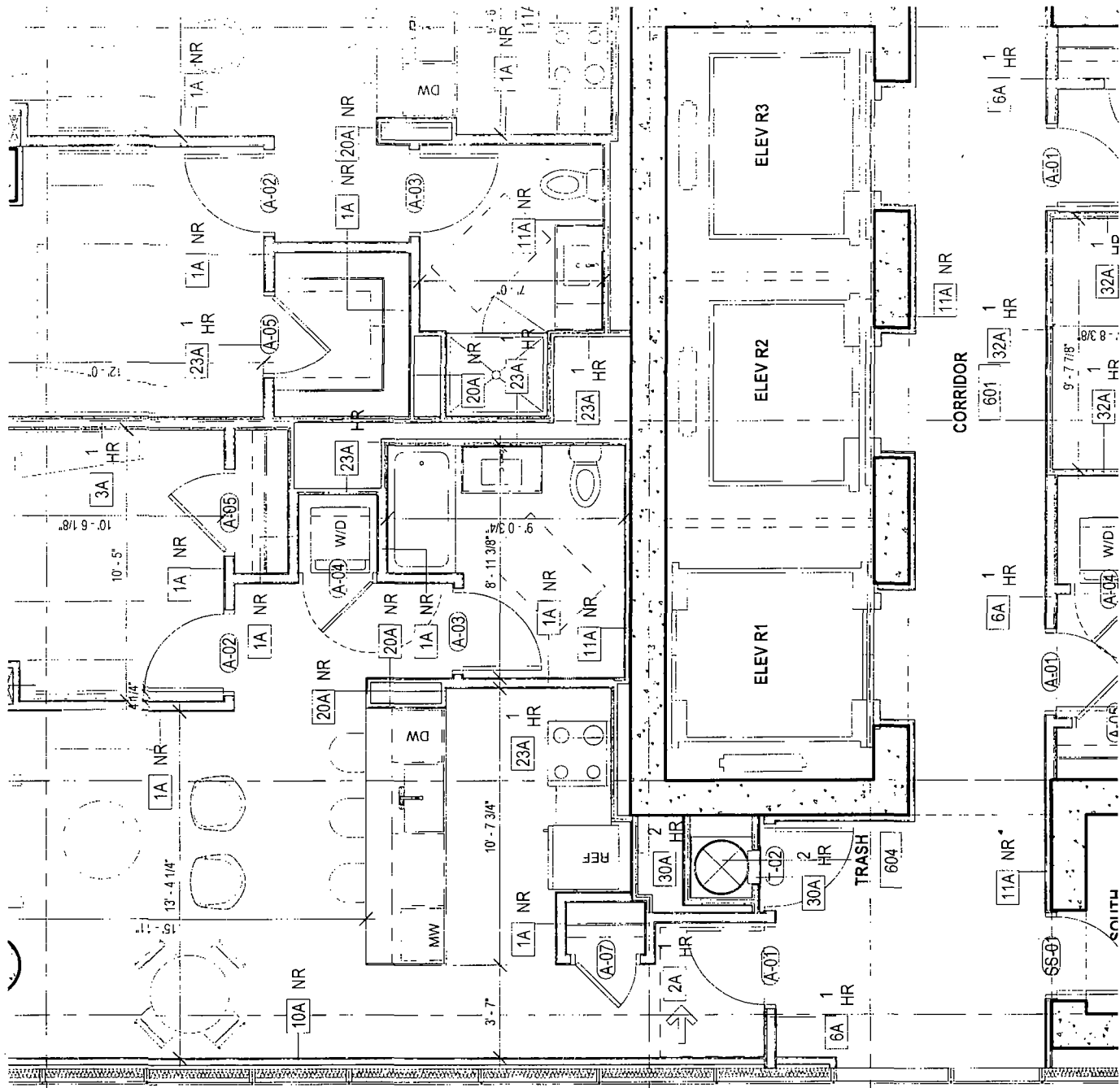

CORRIDOR

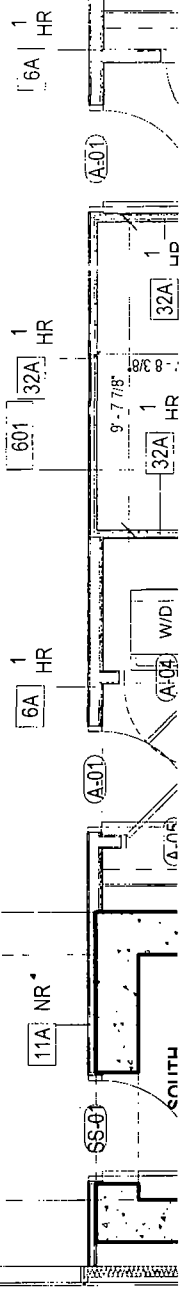

SOUTH

73-10

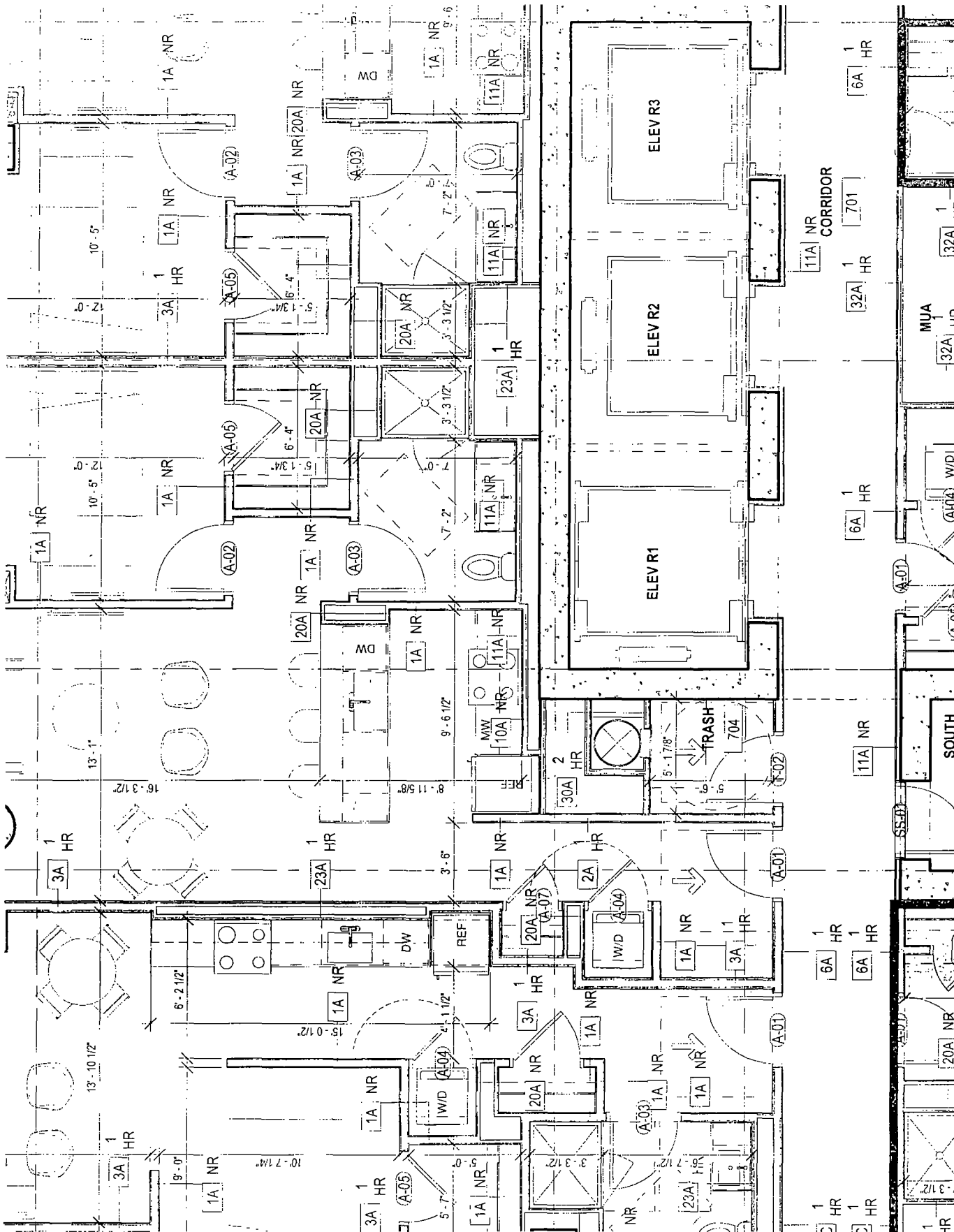

10'-5"

10'-5"

10'-5"

10'-5"

10'-5"

10'-5"

10'-5"

10'-5"

10'-5"

12'-0"

12'-0"

12'-0"

12'-0"

12'-0"

12'-0"

12'-0"

12'-0"

12'-0"

10'-5"

10'-5"

10'-5"

10'-5"

10'-5"

10'-5"

10'-5"

10'-5"

10'-5"

13'-1"

13'-1"

13'-1"

13'-1"

13'-1"

13'-1"

13'-1"

13'-1"

13'-1"

16'-3 1/2"

16'-3 1/2"

16'-3 1/2"

16'-3 1/2"

16'-3 1/2"

16'-3 1/2"

16'-3 1/2"

16'-3 1/2"

16'-3 1/2"

9'-6 1/2"

9'-6 1/2"

9'-6 1/2"

9'-6 1/2"

9'-6 1/2"

9'-6 1/2"

9'-6 1/2"

9'-6 1/2"

9'-6 1/2"

8'-11 5/8"

8'-11 5/8"

8'-11 5/8"

8'-11 5/8"

8'-11 5/8"

8'-11 5/8"

8'-11 5/8"

8'-11 5/8"

8'-11 5/8"

3'-6"

3'-6"

3'-6"

3'-6"

3'-6"

3'-6"

3'-6"

3'-6"

3'-6"

6'-2 1/2"

6'-2 1/2"

6'-2 1/2"

6'-2 1/2"

6'-2 1/2"

6'-2 1/2"

6'-2 1/2"

6'-2 1/2"

6'-2 1/2"

13'-10 1/2"

13'-10 1/2"

13'-10 1/2"

13'-10 1/2"

13'-10 1/2"

13'-10 1/2"

13'-10 1/2"

13'-10 1/2"

13'-10 1/2"

9'-0"

9'-0"

9'-0"

9'-0"

9'-0"

9'-0"

9'-0"

9'-0"

9'-0"

10'-7 1/4"

10'-7 1/4"

10'-7 1/4"

10'-7 1/4"

10'-7 1/4"

10'-7 1/4"

10'-7 1/4"

10'-7 1/4"

10'-7 1/4"

5'-7"

5'-7"

5'-7"

5'-7"

5'-7"

5'-7"

5'-7"

5'-7"

5'-7"

3'-3 1/2"

3'-3 1/2"

3'-3 1/2"

3'-3 1/2"

3'-3 1/2"

3'-3 1/2"

3'-3 1/2"

3'-3 1/2"

3'-3 1/2"

7'-2"

7'-2"

7'-2"

7'-2"

7'-2"

7'-2"

7'-2"

7'-2"

7'-2"

6'-4"

6'-4"

6'-4"

6'-4"

6'-4"

6'-4"

6'-4"

6'-4"

6'-4"

3'-3 1/2"

3'-3 1/2"

3'-3 1/2"

3'-3 1/2"

3'-3 1/2"

3'-3 1/2"

3'-3 1/2"

3'-3 1/2"

3'-3 1/2"

1A NR

1A NR

1A NR

1A NR

1A NR

1A NR

1A NR

1A NR

1A NR

3A HR

3A HR

3A HR

3A HR

3A HR

3A HR

3A HR

3A HR

3A HR

20A NR

20A NR

20A NR

20A NR

20A NR

20A NR

20A NR

20A NR

20A NR

11A NR

11A NR

11A NR

11A NR

11A NR

11A NR

11A NR

11A NR

11A NR

10A NR

10A NR

10A NR

10A NR

10A NR

10A NR

10A NR

10A NR

10A NR

30A HR

30A HR

30A HR

30A HR

30A HR

30A HR

30A HR

30A HR

30A HR

2A HR

2A HR

2A HR

2A HR

2A HR

2A HR

2A HR

2A HR

2A HR

1A NR

1A NR

1A NR

1A NR

1A NR

1A NR

1A NR

1A NR

1A NR

3A HR

3A HR

3A HR

3A HR

3A HR

3A HR

3A HR

3A HR

3A HR

6A HR

6A HR

6A HR

6A HR

6A HR

6A HR

6A HR

6A HR

6A HR

11A NR

11A NR

11A NR

11A NR

11A NR

11A NR

11A NR

11A NR

11A NR

701 HR

701 HR

701 HR

701 HR

701 HR

701 HR

701 HR

701 HR

701 HR

32A HR

32A HR

32A HR

32A HR

32A HR

32A HR

32A HR

32A HR

32A HR

MUA HR

MUA HR

MUA HR

MUA HR

MUA HR

MUA HR

MUA HR

MUA HR

MUA HR

32A HR

32A HR

32A HR

32A HR

32A HR

32A HR

32A HR

32A HR

32A HR

WID

WID

WID

WID

WID

WID

WID

WID

WID

SOUTH

SOUTH

SOUTH

SOUTH

SOUTH

SOUTH

SOUTH

SOUTH

SOUTH



# 907 TYPE A

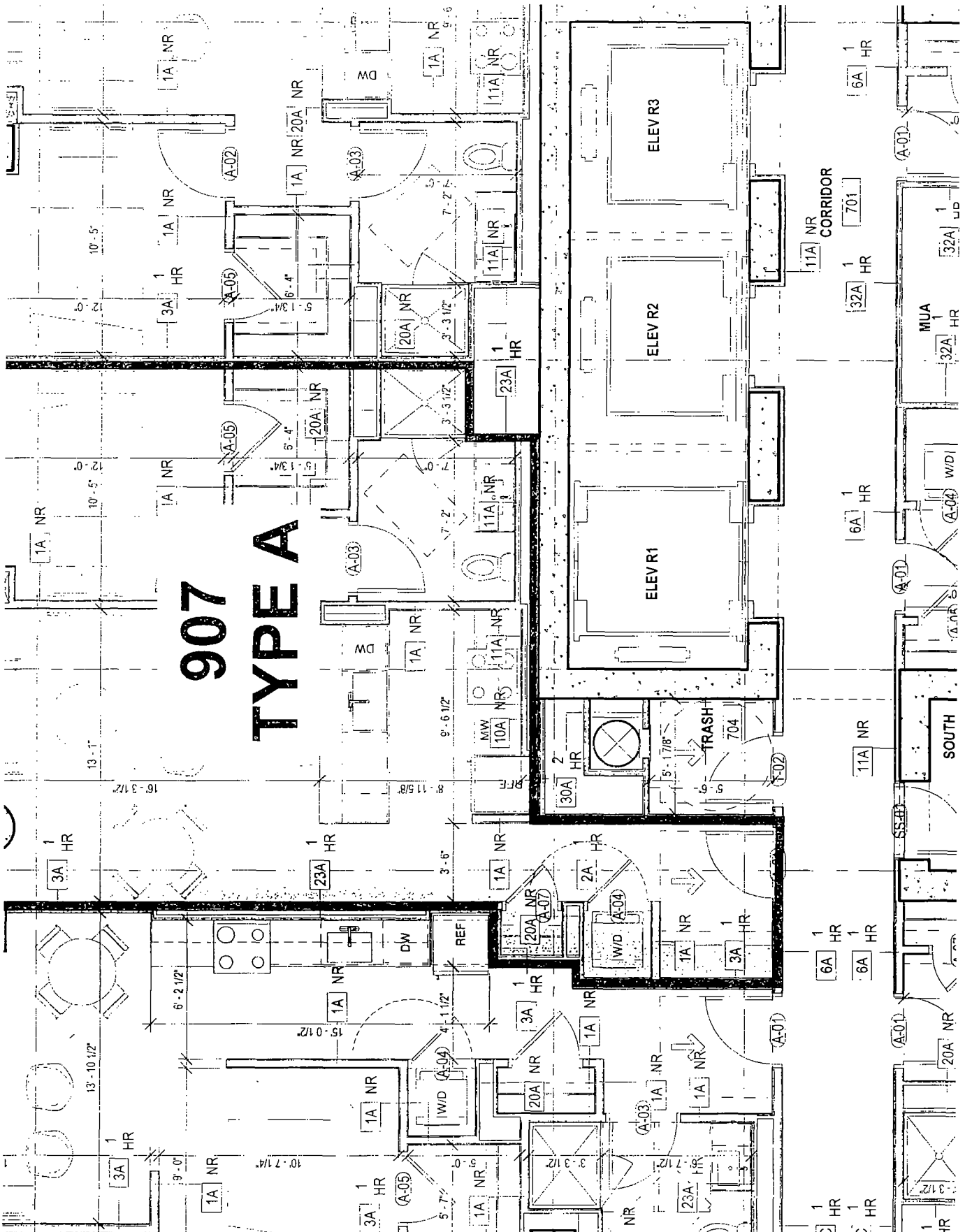











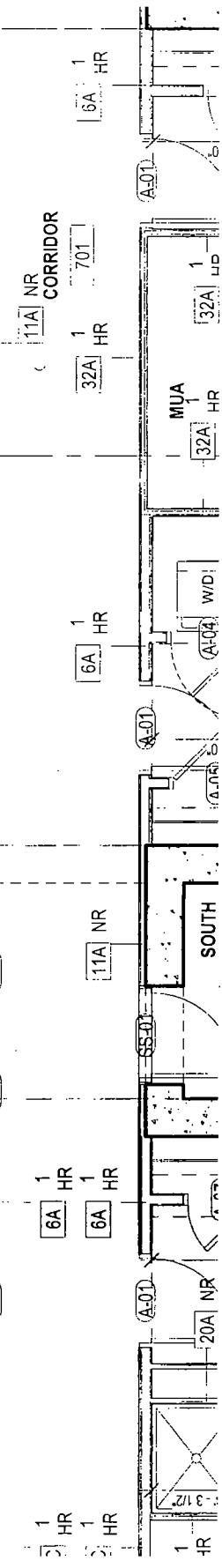
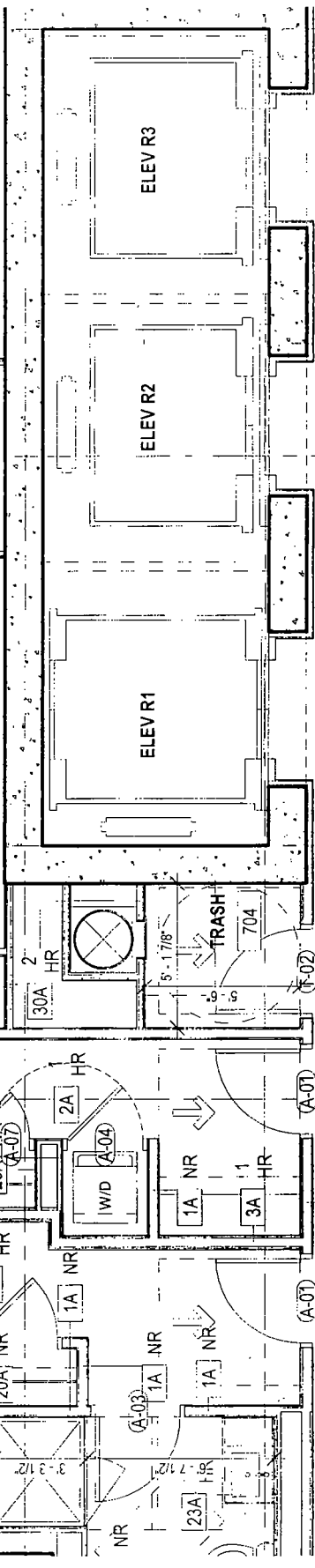
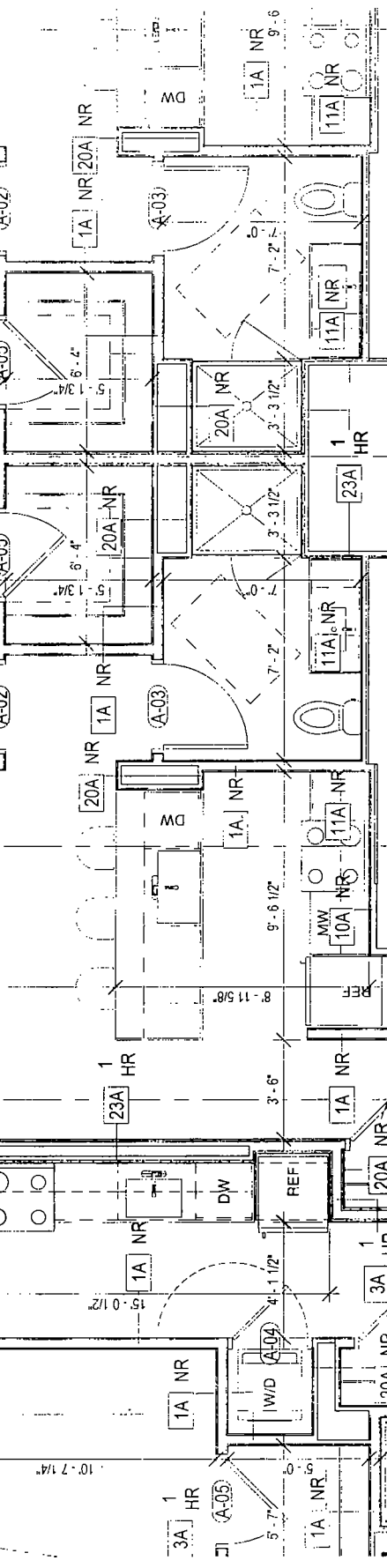
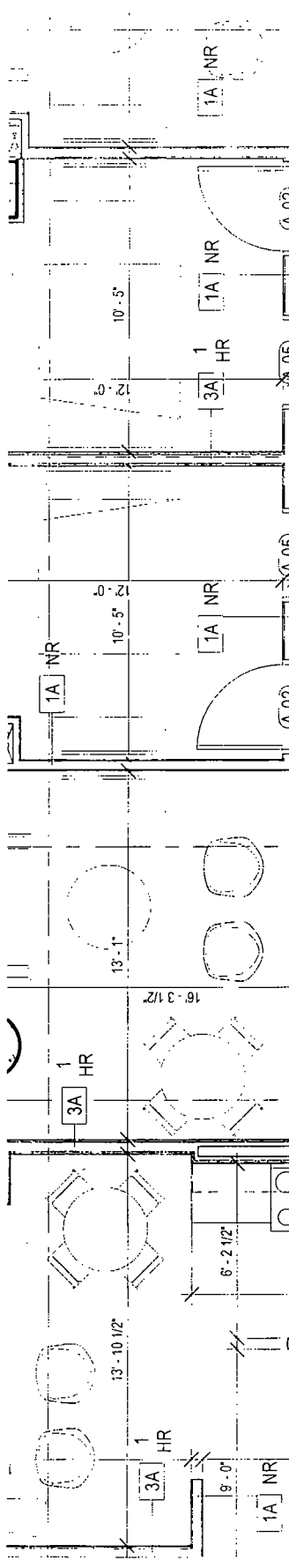
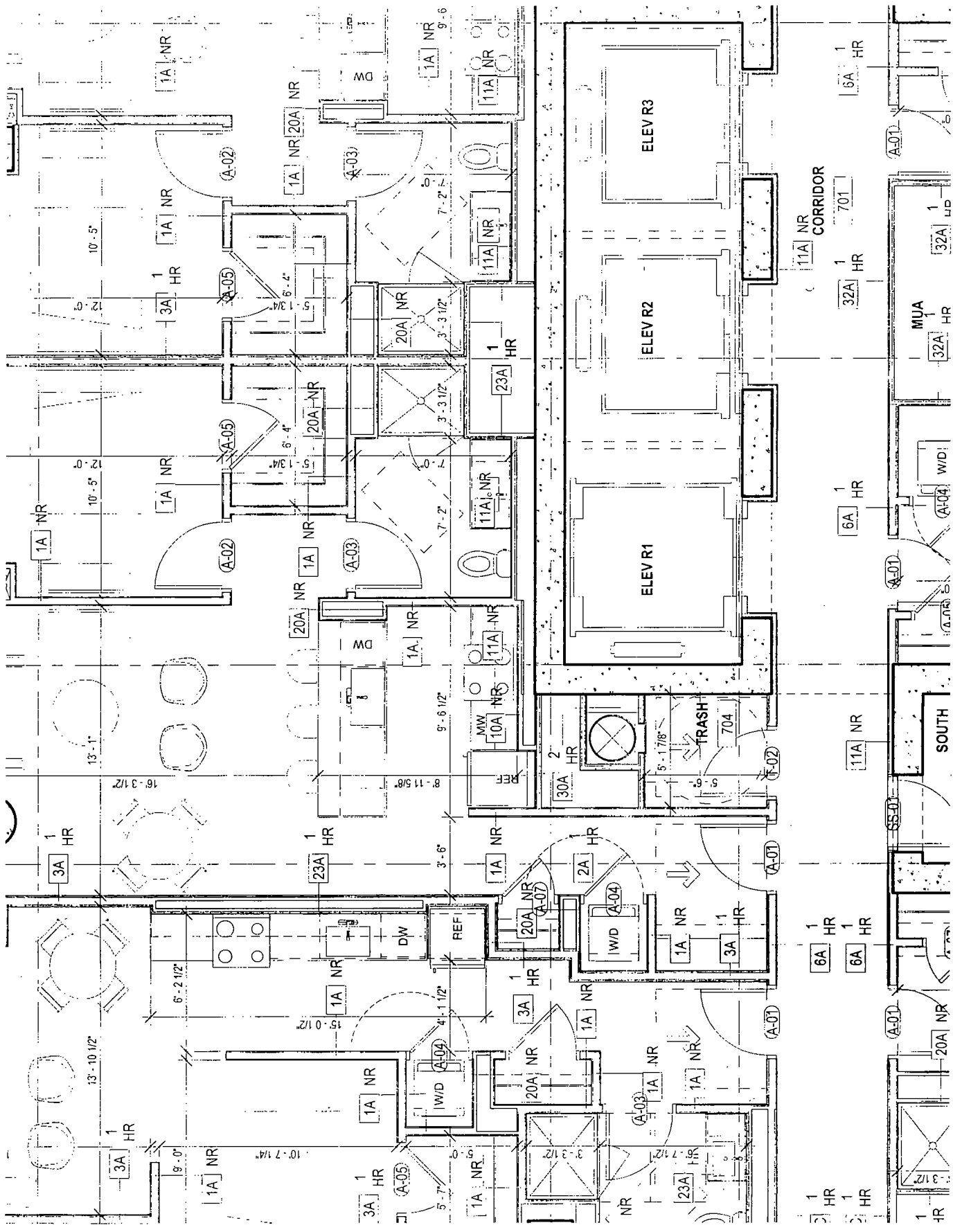

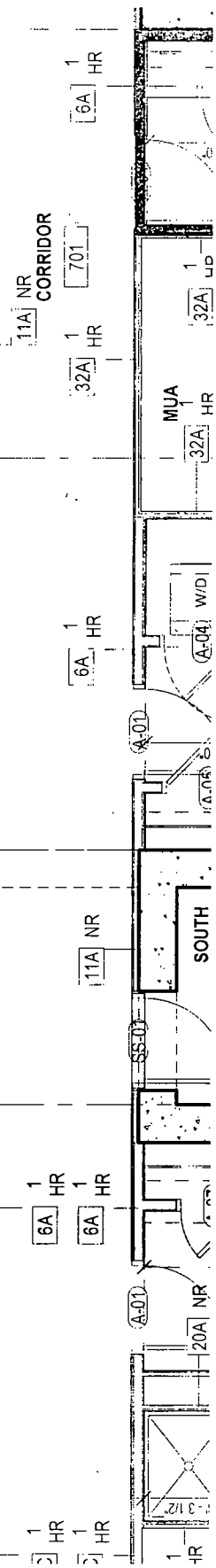
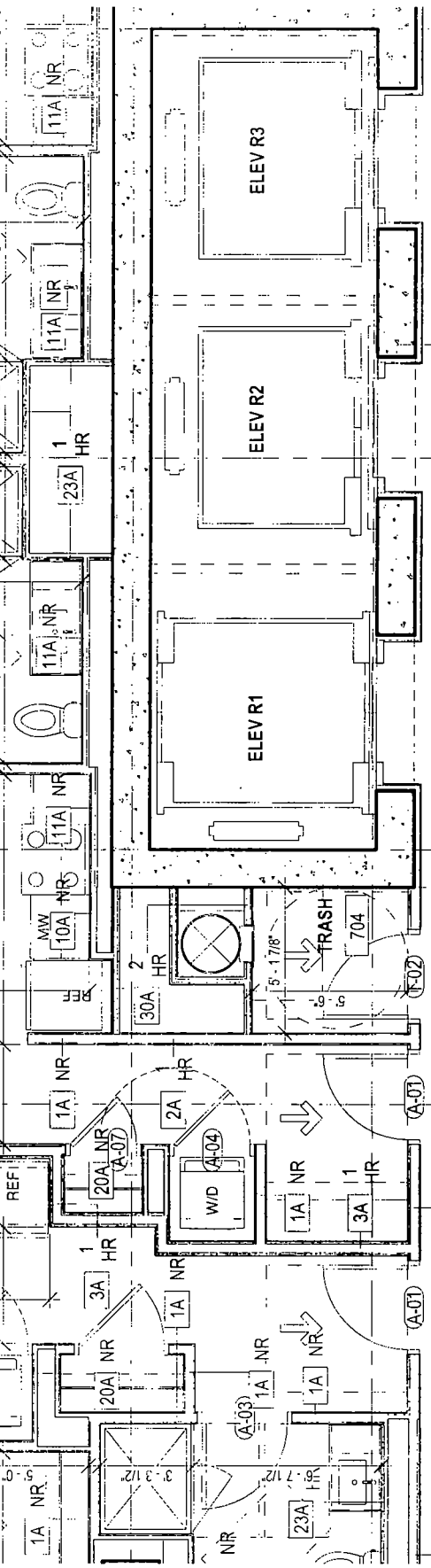
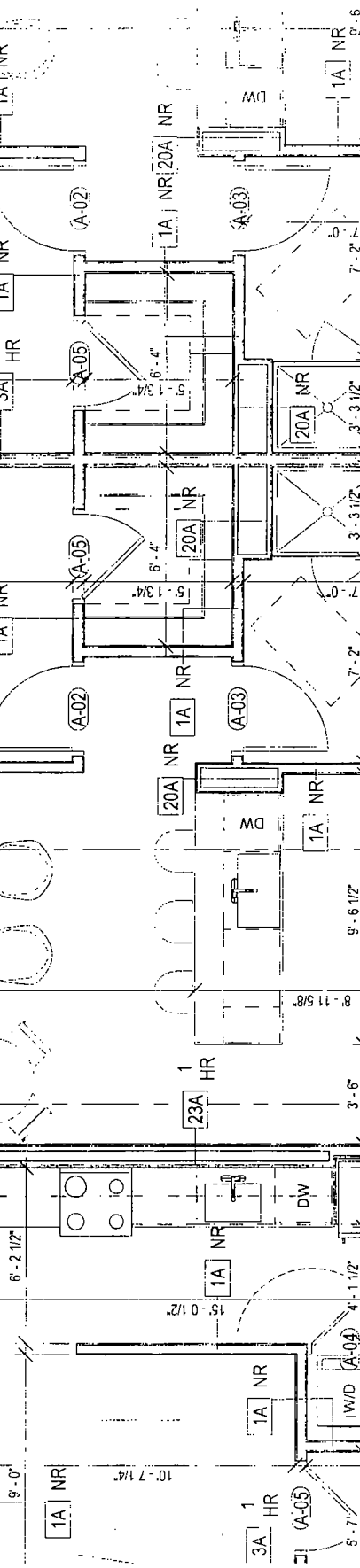
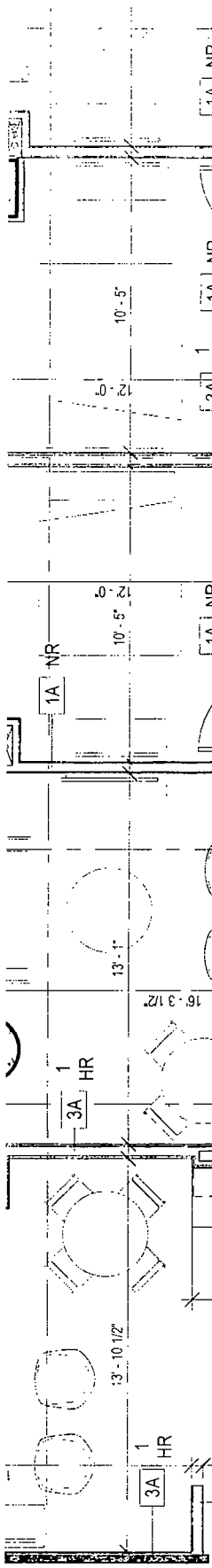
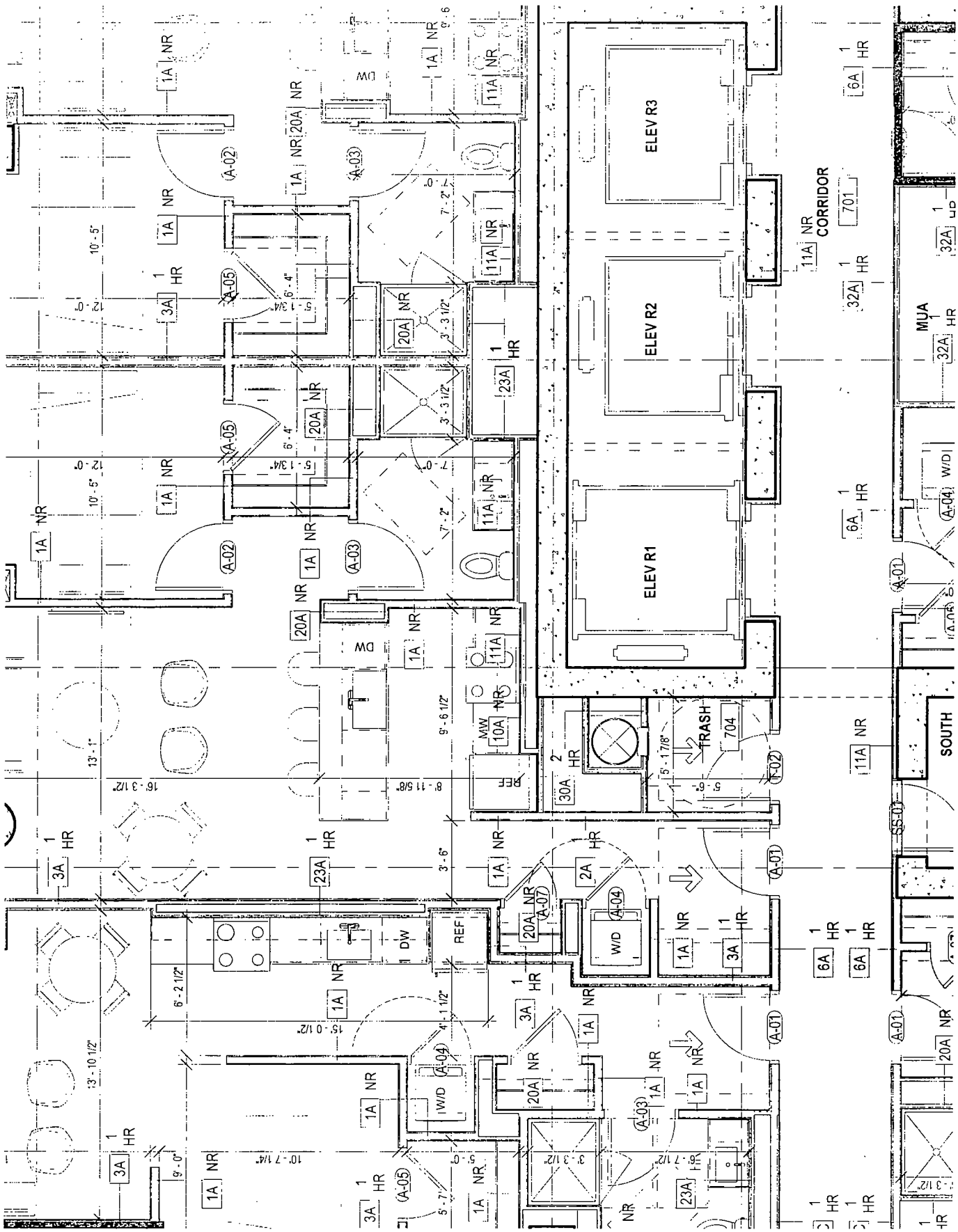



# 1907 TYPE A

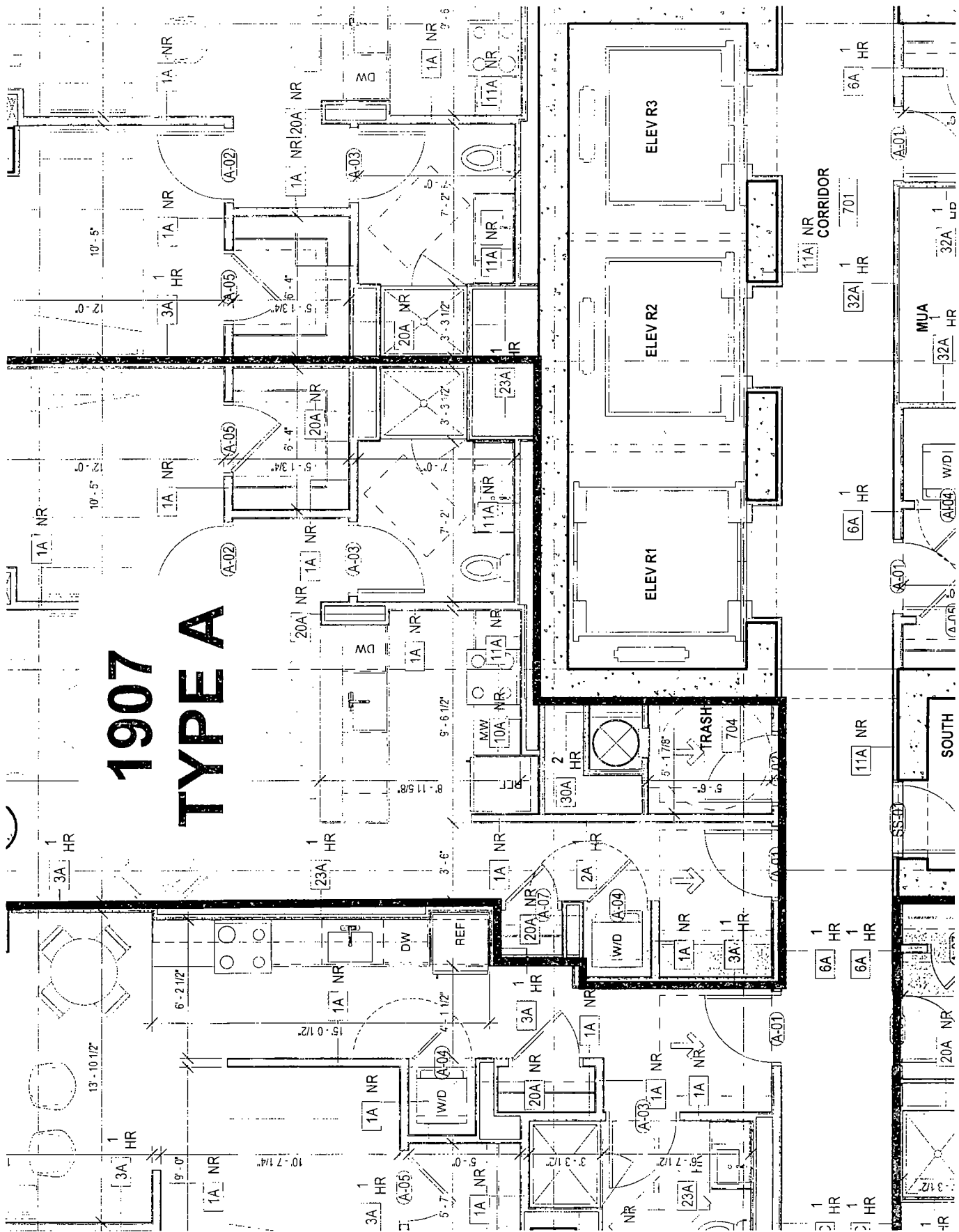





# 230 TYPE

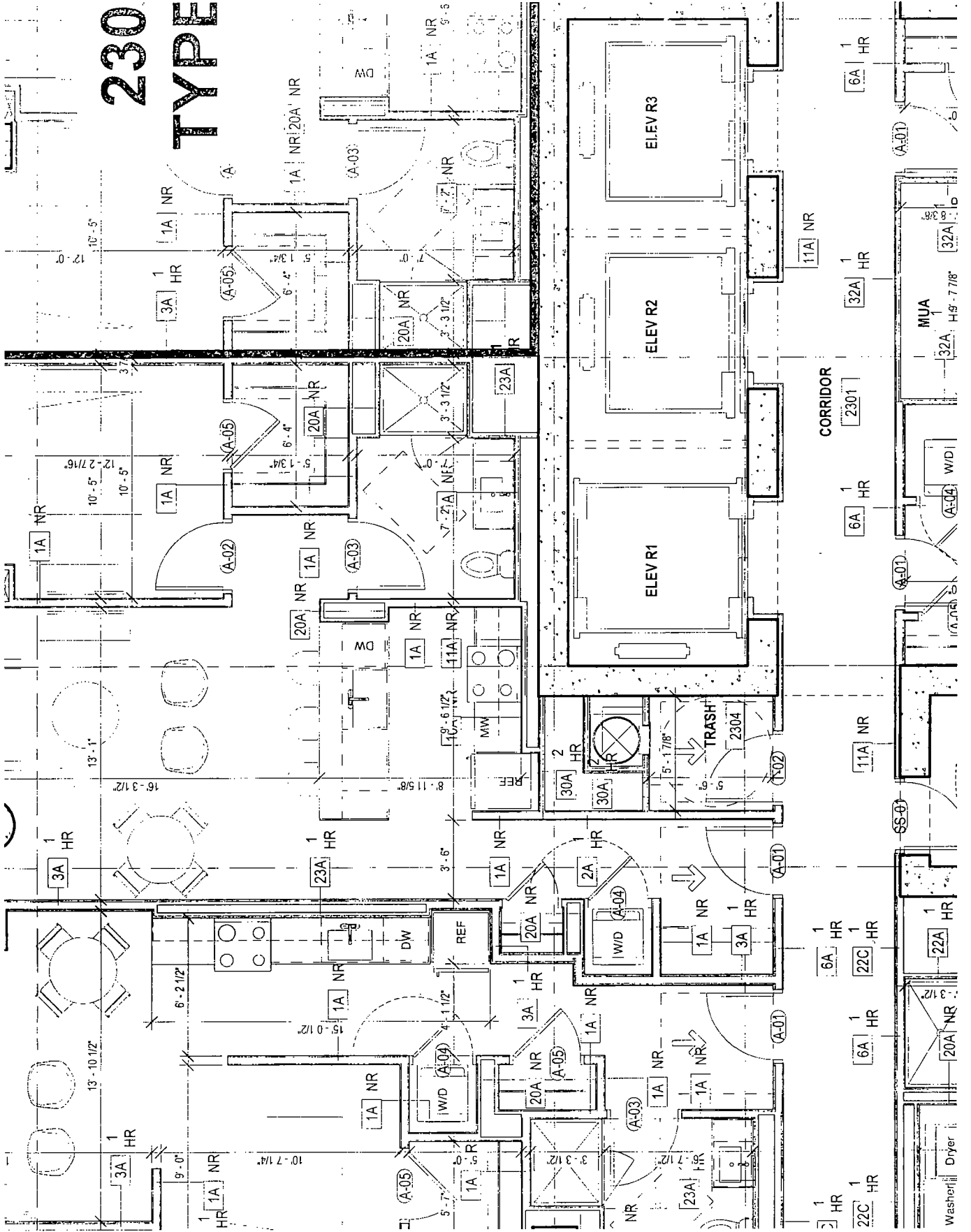



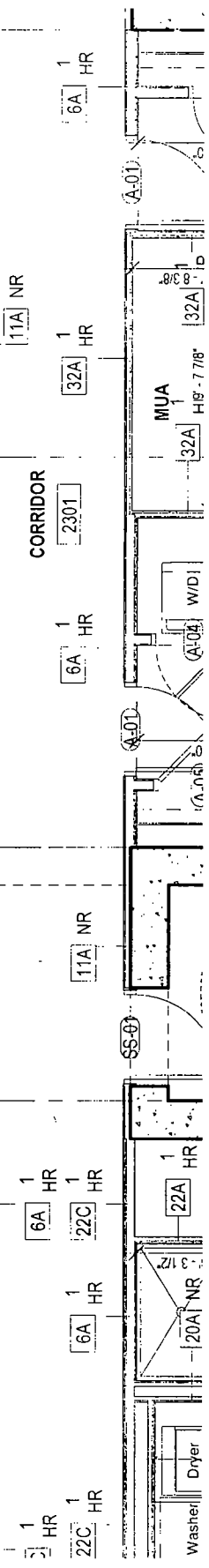
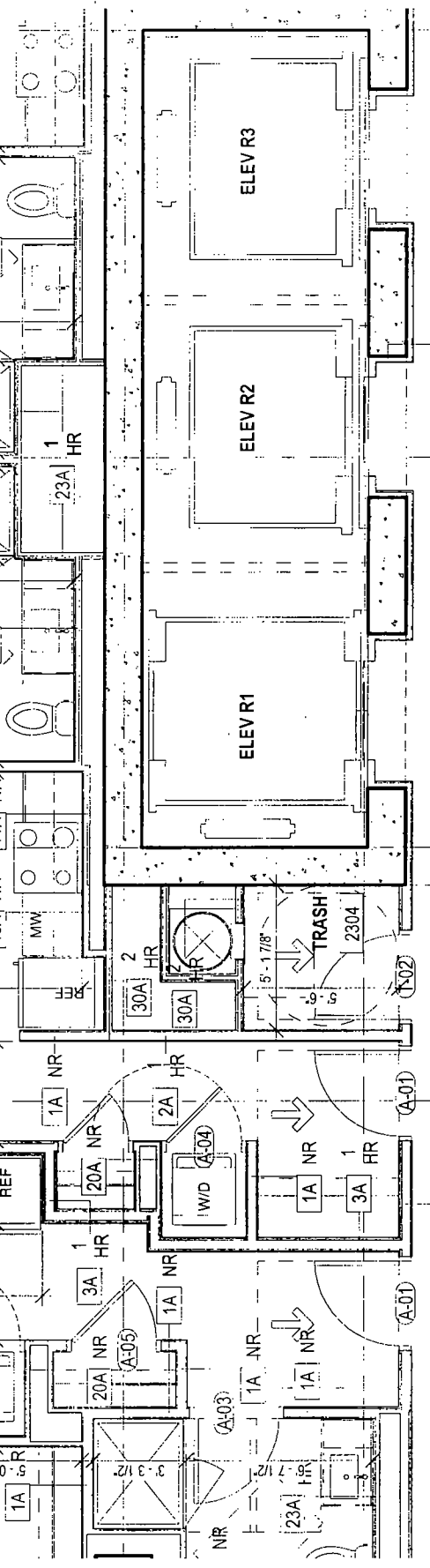
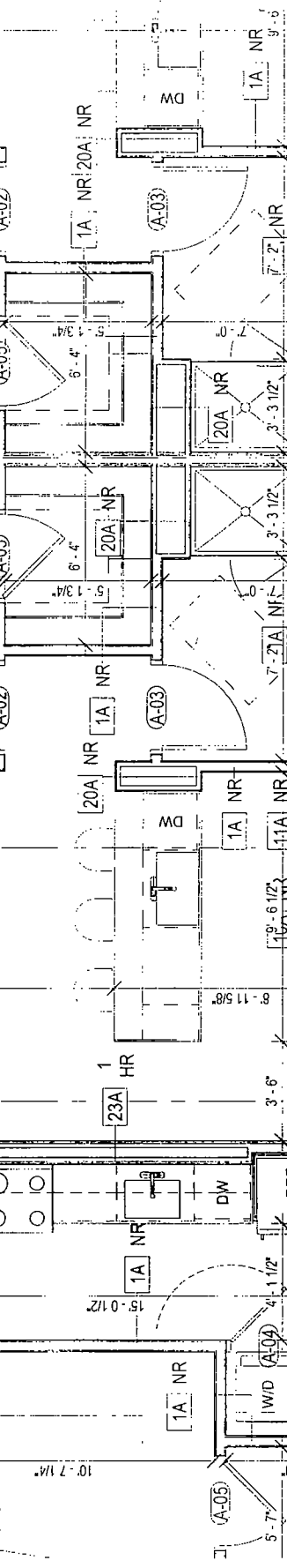
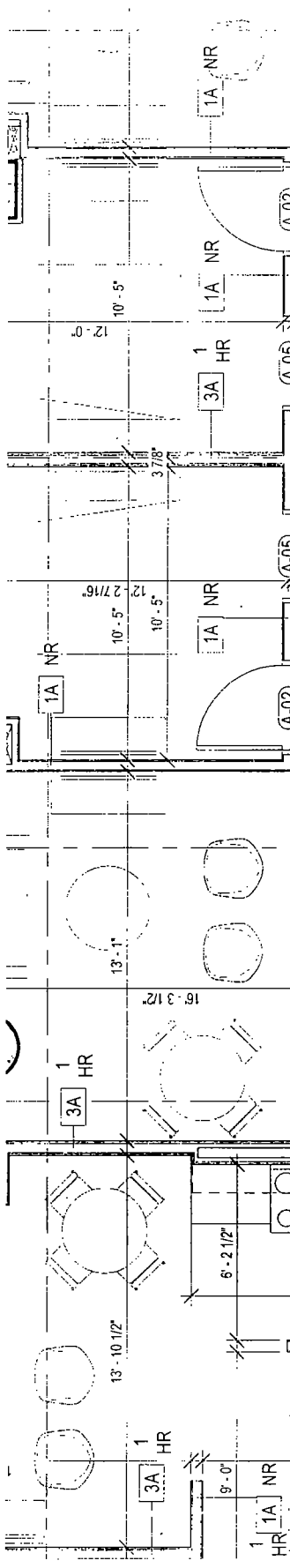
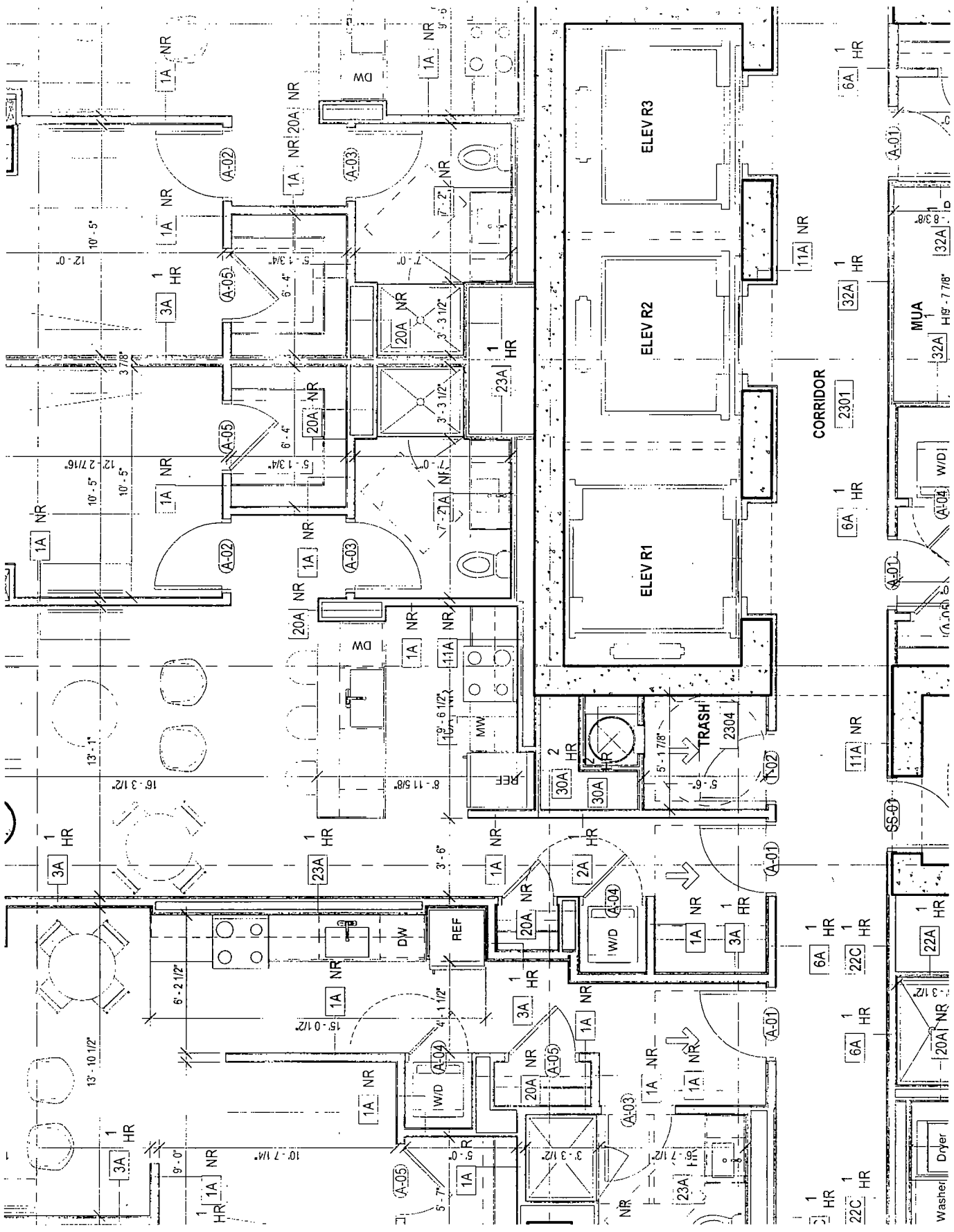



#20631

DEPARTMENT OF PLANNING AND DEVELOPMENT  
CITY OF CHICAGO

**MEMORANDUM**

To: Alderman Tom Tunney  
Chairman, City Council Committee on Zoning

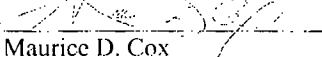
From:   
Maurice D. Cox  
Chicago Plan Commission

Date: September 16, 2021

Re: Proposed Residential-Business Planned Development – 160 N. Morgan St.

---

On September 16, 2021, the Chicago Plan Commission recommended approval of the proposed Planned Development, submitted by 160 N. Morgan, LLC. A copy of the proposed ordinance, planned development statements, bulk table and exhibits are attached. I would very much appreciate your assistance in having this introduced at the next possible City Council Committee on Zoning.

Also enclosed is a copy of the staff report to the Plan Commission which includes the Department of Planning and Development, Bureau of Zoning recommendation and a copy of the resolution. If you have any questions in this regard, please do not hesitate to contact Joshua Son at 312-744-2780.

Cc: PD Master File (Original PD, copy of memo)