



# Office of the City Clerk

City Hall  
121 N. LaSalle St.  
Room 107  
Chicago, IL 60602  
www.chicityclerk.com

## Legislation Details (With Text)

**File #:** O2016-6739  
**Type:** Ordinance                      **Status:** Passed  
**File created:** 9/14/2016                      **In control:** City Council  
**Final action:** 10/5/2016

**Title:** Awning(s) for Boutique Cleaners  
**Sponsors:** Pawar, Ameya  
**Indexes:** Awnings

**Attachments:**

Date	Ver.	Action By	Action	Result
10/5/2016	1	City Council	Passed	Pass
9/29/2016	1	Committee on Transportation and Public Way	Recommended to Pass	Pass
9/14/2016	1	City Council	Referred	

ORDINANCE BOUTIQUE  
CLEANERS Acct. No. 405317 - 1  
Permit No. 1122854

*Be It Ordained by the City Council of the City of Chicago:*

SECTION 1. Permission and authority are hereby given and granted to BOUTIQUE CLEANERS, upon the terms and subject to the conditions of this ordinance to construct, install, maintain and use one (1) Awning(s) projecting over the public right-of-way adjacent to its premises known as 3405 N. Paulina St..

Said Awning(s) at N. Paulina measure(s):  
One (1) at thirteen (13) feet in length, and four (4) feet in width for a total of fifty-two (52) square feet.

The location of said privilege shall be as shown on prints kept on file with the Department of Business Affairs and Consumer Protection and the Office of the City Clerk.

Said privilege shall be constructed in accordance with plans and specifications approved by the Zoning Department - Signs.

This grant of privilege in the public way shall be subject to the provisions of Section 10-28-015 and all other required provisions of the Municipal Code of Chicago.

The grantee shall pay to the City of Chicago as compensation for the privilege #1122854 herein granted the sum of fifty (\$50.00) per annum in advance.

A 25% penalty will be added for payments received after due date.

The permit holder agrees to hold the City of Chicago harmless for any damage, relocation or replacement costs associated with damage, relocation or removal of private property caused by the City performing work in the public way.

Page 1

Authority herein given and granted for a period of five (5) years from and after Date of Passage.

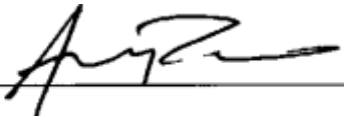
Alderman   
Ameya Pawar 47th Ward

(Page 3 of 3)

Awning Rendering.jpg

AWNING ON FRONT OF WALL

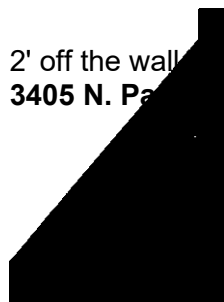

# 'CLEANERS

773-321-6868

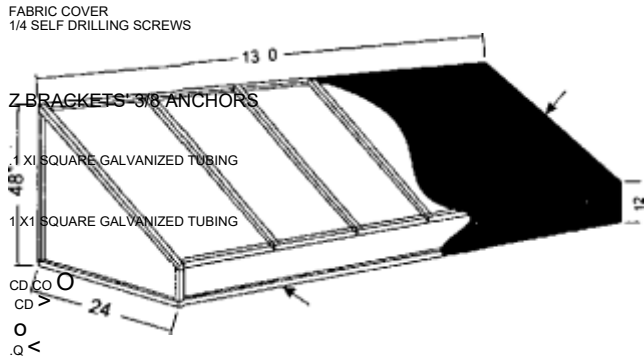

BRICK WALL-'', qV, J

0)  
X

# P&S signs

5500 N. Kudzir. Ave Chicago, IL S0S25 y3-2S7-«007 ] salesStlasigns.com

\* Don't drill on teracota

Client	Boutique Cleaners	Landlord
Address	3405 N Paulina	Address

Start Date 00/00/0000 •  
 Last Revision 00/00/0000  
 Job# 00000  
 Drawing? 00000a v1 s1 /  
 e1 Page t of 2

Client Approval «  
 Landlord Approval

Sales Rep  
 Seung Park  
 Designer

Tel	Tel
Email	Email

E32  
USTE

COPYRIGHT 2013 BY TFA Signs THIS RENDERING IS THE PROPERTY OF TFA SIGNS IMC AND THE PARTY WHICH REQUESTED THE RENDERING IT IS AN UNPUBLISHED ORIGINAL DRAWING NOT TO BE REPRODUCED OR EXHIBITED WITHOUT THE CONSENT OF TFA SIGNS INC

[https://mail.google.com/mail/u/0Plab=wmtnbox/154ca38l03064174"projectcr=1](https://mail.google.com/mail/u/0Plab=wmtnbox/154ca38l03064174)

# 7t



Department of Business Affairs and Consumer Protection  
 Service Center - Public Way Use Unit City Hall - 121 N. LaSalle Street, Room 800 • Chicago, IL 60602 312-74-GOMZ/312-744-6249 • (312) 744-1944 (TTY)  
<http://www.cityofchicago.org/bacp>

09/14/2016

Alderman Ameya Pawar Ward # 47 City of  
 Chicago City Hall, Room 200 121 North  
 LaSalle Street Chicago, Illinois 60602

**Re: An ordinance to use and maintain a portion of the public right-of-way for one (1) awning(s) for BOUTIQUE CLEANERS, adjacent to the premises known as 3405 N. Paulina St..**

**Dear Alderman Ameya Pawar:**

The applicant referenced above has requested the use of the public right-of-way for a awning(s). An ordinance has been prepared by the Department of Business Affairs and Consumer Protection - Small Business Center -Public Way Use Unit for presentation to the City Council. Because this request was made for properties located in your ward, as approved by you as per the attached, I respectfully request that you introduce the attached ordinance at the next City Council meeting.

If you have any questions regarding this ordinance, please contact Anthony Bertuca at (312) 744-5506.

**Department of Business Affairs and Consumer Protection**